

Technical Support Center: Refining NSC12 Delivery Methods for Tumors

Author: BenchChem Technical Support Team. **Date:** April 2026

Compound of Interest

Compound Name: NSC12
Cat. No.: B10752732

[Get Quote](#)

This technical support center provides troubleshooting guides and frequently asked questions (FAQs) for researchers, scientists, and drug development professionals working on refining the delivery methods of **NSC12** for tumor-targeted therapy.

Frequently Asked Questions (FAQs)

Q1: What is **NSC12** and what is its primary mechanism of action?

A1: **NSC12** is an experimental, orally available small molecule that functions as a pan-fibroblast growth factor (FGF) trap.^[1] Its primary mechanism of action is to inhibit the interaction between FGF2 and its receptor (FGFR), thereby blocking downstream signaling pathways that are crucial for tumor cell proliferation, angiogenesis, and survival in FGF-dependent cancers.^{[1][2]} It has shown promising antitumor activity in preclinical models of lung cancer and multiple myeloma.^{[1][3]}

Q2: What are the known challenges associated with **NSC12** delivery?

A2: While **NSC12** has the advantage of being orally available, challenges in its experimental application can include issues with solubility in aqueous solutions for in vitro assays and achieving optimal biodistribution to the tumor site with minimal off-target accumulation when

developing novel parenteral formulations.[2] One study on a chemically modified version of **NSC12** suggests the original compound might have off-target effects related to estrogen receptor binding.[3]

Q3: Are there any known stability issues with **NSC12**?

A3: The steroidal derivative **NSC12** is described as being orally available, which suggests a degree of stability in biological systems.[1] However, like many small molecules, it may be susceptible to degradation under certain pH, light, or temperature conditions. For a different compound, also identified as NSC-281612, chemical instability in aqueous solutions has been reported, with a half-life of around 24 hours in a pH range of 2-11.[4][5][6] It is crucial for researchers to perform stability studies on their specific **NSC12** formulation.

Q4: What are the recommended starting points for in vivo dosing of **NSC12**?

A4: In murine models, parenteral (intraperitoneal) administration of **NSC12** has been tested at doses ranging from 2.5 to 10 mg/kg.[2] These doses have been shown to significantly decrease tumor weight and vascularization.[2] For novel formulations, it is recommended to conduct a dose-escalation study to determine the maximum tolerated dose (MTD) and optimal therapeutic window.

Troubleshooting Guides

Problem 1: Poor Solubility of **NSC12** in Aqueous Buffers for In Vitro Assays

Potential Cause	Suggested Solution
Inherent Hydrophobicity	Prepare a high-concentration stock solution of NSC12 in an organic solvent such as fresh, moisture-free DMSO.[2] For working solutions, dilute the stock in your cell culture medium, ensuring the final DMSO concentration is non-toxic to the cells (typically <0.5%). Vortexing or using a hot water bath may aid dissolution.[2]
Precipitation in Media	Decrease the final concentration of NSC12 in the assay. If precipitation persists, consider using a solubilizing agent. For a different, poorly soluble compound (NSC-281612), cyclodextrins like (SBE)7m- β -CD and HP- β -CD significantly enhanced solubility.[4] This approach could be explored for NSC12.
Incorrect Solvent	Ensure the DMSO used is of high quality and anhydrous, as absorbed moisture can reduce solubility.[2]

Problem 2: Low Efficacy or Inconsistent Results in In Vitro Cell-Based Assays

Potential Cause	Suggested Solution
Sub-optimal Drug Concentration	Perform a dose-response experiment to determine the IC50 value for your specific cancer cell line. Effective concentrations in the low micromolar range (e.g., 1.0 to 3.0 μ M) have been reported for some cell lines.[2]
Cell Line Insensitivity	Confirm that your chosen cell line is dependent on the FGF signaling pathway. Cell lines that do not rely on this pathway for proliferation or survival will likely be resistant to NSC12.
Assay Parameters	The observed inhibitory activity of anticancer drugs can be influenced by cell concentration and the type of medium or serum used.[7] Standardize these parameters across experiments to ensure reproducibility.
Drug Degradation	Prepare fresh dilutions of NSC12 from the stock solution for each experiment to avoid potential degradation in aqueous media over time.

Problem 3: Low Tumor Accumulation and High Off-Target Biodistribution of Novel NSC12 Formulations In Vivo

Potential Cause	Suggested Solution
Rapid Clearance	For nanoparticle-based delivery systems, consider surface modification with polyethylene glycol (PEG) to improve blood circulation time and enhance tumor accumulation through the Enhanced Permeability and Retention (EPR) effect.[8]
Non-specific Uptake	If off-target accumulation is observed in specific organs (e.g., liver, spleen), consider active targeting by conjugating ligands to your delivery vehicle that bind to receptors overexpressed on your target tumor cells.[9][10]
Particle Size and Properties	The size and surface charge of nanoparticles can significantly affect their biodistribution.[11] Aim for particle sizes in the range of 50-200 nm for optimal tumor accumulation. Characterize your formulation thoroughly for size, polydispersity, and zeta potential.
Tumor Model Variability	Tumor accumulation can vary significantly depending on the tumor type and its location (e.g., subcutaneous vs. orthotopic).[11] Ensure your animal model is appropriate and consider the tumor microenvironment's characteristics.

Quantitative Data Summary

Table 1: In Vitro Efficacy and Binding Data for **NSC12** and Related Compounds

Compound/Formulation	Assay/Parameter	Cell Line/Target	Result	Reference
NSC12	Inhibition of FGF2 binding to FGFR	-	ID50 ~30 μM	[2]
NSC12	Binding Affinity (Kd)	FGF3, FGF4, FGF6, FGF8, FGF16, FGF18, FGF20, FGF22	~16 to ~120 μM	[2]
NSC12	Cell Proliferation Inhibition	KATO III cells	Optimal dose 1.0 or 3.0 μM	[2]
HH-N25 (NSC Derivative)	IC50	Human breast cancer cell lines	0.045 \pm 0.01 to 4.21 \pm 0.05 μM	[12]
NSC-281612 with HP- β -CD	Apparent Binding Constant	-	1,486 M^{-1}	[4]
NSC-281612 with (SBE)7m- β -CD	Apparent Binding Constant	-	2,740 M^{-1}	[4]

Table 2: General Nanoparticle Tumor Accumulation Data (for reference)

Nanoparticle Size	Tumor Model	Tumor Location	Tumor Accumulation (% Recovered Dose)	Reference
55 x 60 nm	A431, SKOV3, 344SQ	Flank	~15-38% (344SQ), ~3-15% (others)	[11]
80 x 180 nm	A431, SKOV3, 344SQ	Flank	~15-38% (344SQ), ~3-15% (others)	[11]
80 x 320 nm	A431, SKOV3, 344SQ	Flank	~15-38% (344SQ), ~3-15% (others)	[11]

Experimental Protocols

1. Protocol: In Vitro Cell Proliferation (MTT) Assay

This protocol is adapted from methodologies used to assess the efficacy of anticancer agents. [2][13]

- **Cell Seeding:** Plate cancer cells (e.g., KATO III) in 96-well plates at a density of 1×10^4 cells/well in RPMI medium supplemented with 1% FBS. Allow cells to adhere for 24 hours.
- **Drug Treatment:** Prepare serial dilutions of **NSC12** from a DMSO stock. Treat cells with varying concentrations of **NSC12** (e.g., 0.1 μ M to 100 μ M) or vehicle control (DMSO).
- **Incubation:** Incubate the plates for 72 hours at 37°C in a humidified incubator with 5% CO₂.
- **MTT Addition:** Add 10 μ L of MTT reagent (5 mg/mL in PBS) to each well and incubate for 4 hours.
- **Formazan Solubilization:** Add 100 μ L of solubilization solution (e.g., 10% SDS in 0.01 M HCl) to each well and incubate overnight to dissolve the formazan crystals.

- Data Acquisition: Measure the optical density (OD) at 595 nm with a reference wavelength of 630 nm using a microplate reader.
- Analysis: Calculate the percentage of cell viability relative to the vehicle control and determine the IC50 value.

2. Protocol: In Vivo Tumor Xenograft Model and Biodistribution Study

This protocol provides a general framework for evaluating a novel **NSC12** formulation.[\[2\]](#)[\[8\]](#)[\[11\]](#)

- Tumor Implantation: Subcutaneously inject a suspension of human cancer cells (e.g., 1×10^6 cells in Matrigel) into the flank of immunodeficient mice (e.g., NOD/SCID or nude mice).
- Tumor Growth: Allow tumors to grow to a palpable size (e.g., 100 mm³).
- Drug Administration: Administer the **NSC12** formulation (e.g., encapsulated in fluorescently labeled nanoparticles) via intravenous or intraperitoneal injection at a predetermined dose. Include control groups (e.g., free **NSC12**, empty nanoparticles).
- Biodistribution Analysis (24h post-injection):
 - Humanely euthanize the mice.
 - Perfuse the circulatory system with saline.
 - Excise the tumor and major organs (liver, spleen, kidneys, lungs, heart, brain).
 - Weigh each organ.
 - Quantify the amount of **NSC12** or the delivery vehicle in each organ using an appropriate method (e.g., fluorescence imaging for labeled nanoparticles, LC-MS/MS for the drug).
 - Express the data as a percentage of the injected dose per gram of tissue (%ID/g).

Visualizations

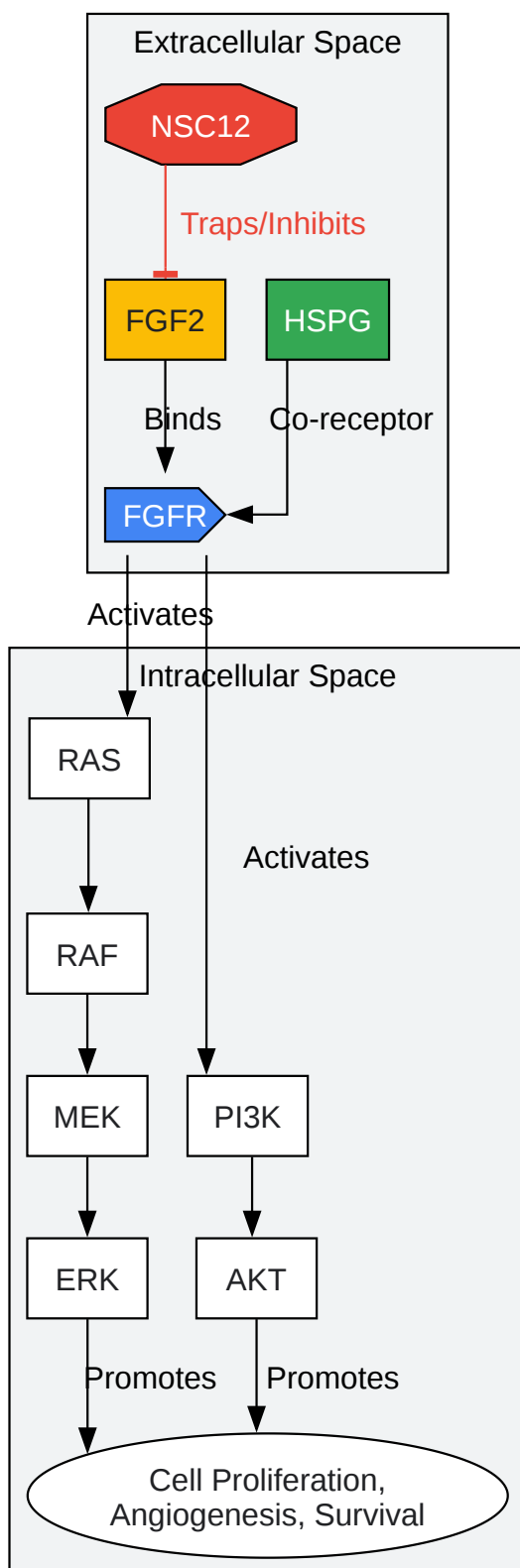

[Click to download full resolution via product page](#)

Caption: **NSC12** inhibits the FGF signaling pathway by trapping FGF2.

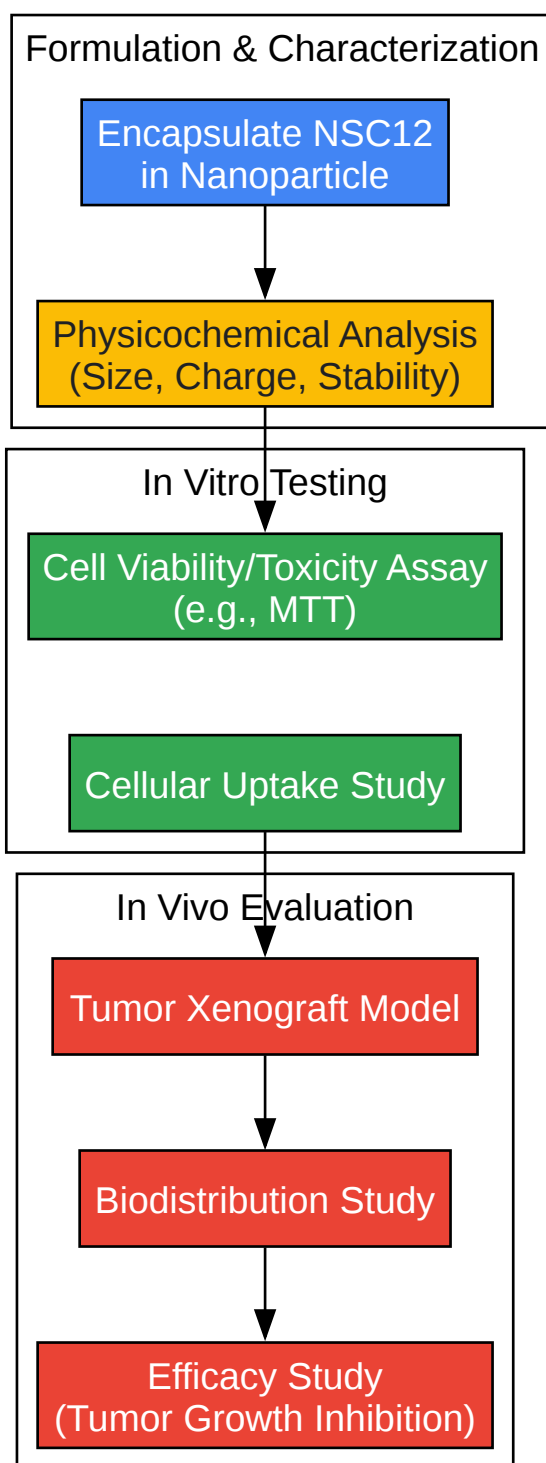

[Click to download full resolution via product page](#)

Caption: Workflow for developing and testing a novel **NSC12** delivery system.

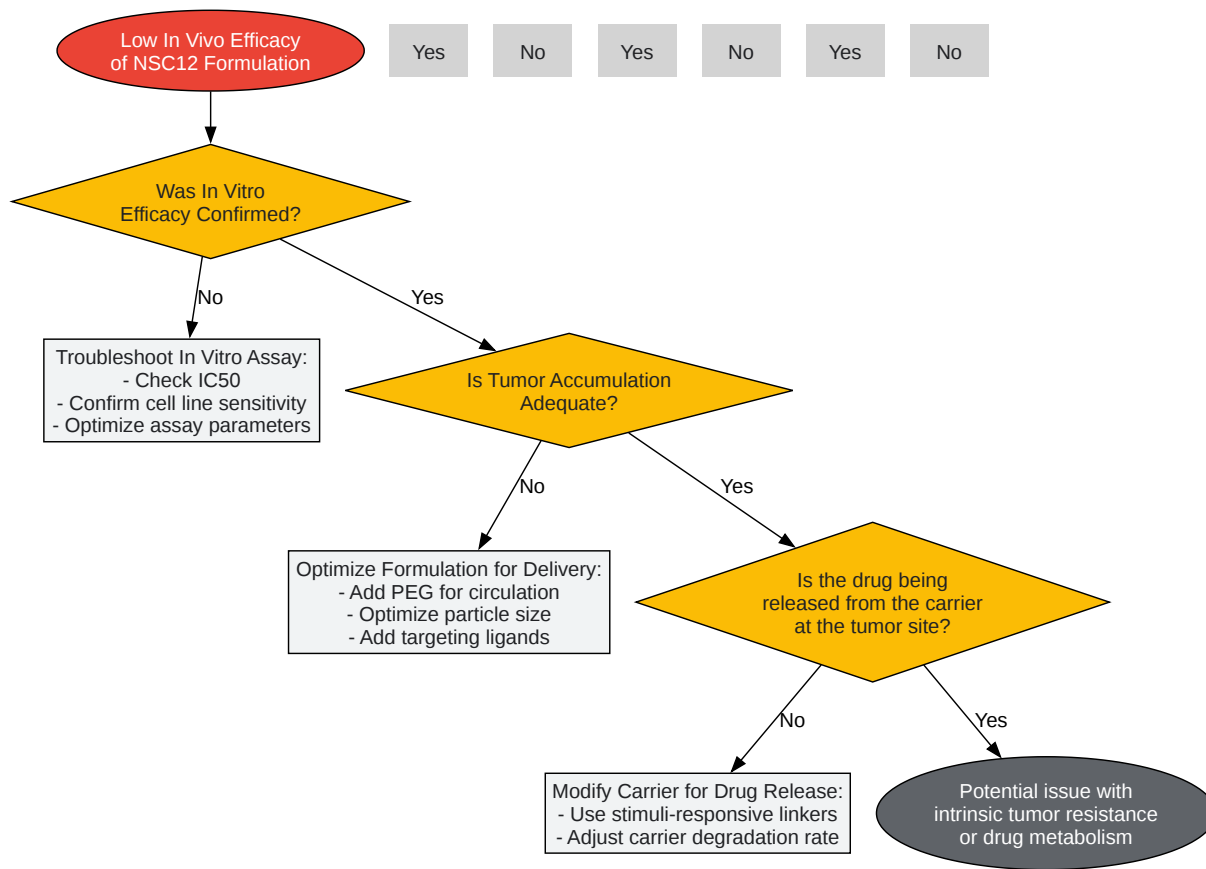

[Click to download full resolution via product page](#)

Caption: Troubleshooting low in vivo efficacy of **NSC12** formulations.

Need Custom Synthesis?

BenchChem offers custom synthesis for rare earth carbides and specific isotopic labeling.

Email: info@benchchem.com or [Request Quote Online](#).

References

- 1. Synthesis, Structural Elucidation, and Biological Evaluation of NSC12, an Orally Available Fibroblast Growth Factor (FGF) Ligand Trap for the Treatment of FGF-Dependent Lung Tumors - PubMed [pubmed.ncbi.nlm.nih.gov]
- 2. [selleckchem.com](https://www.selleckchem.com) [[selleckchem.com](https://www.selleckchem.com)]
- 3. Chemical modification of NSC12 leads to a specific FGF-trap with antitumor activity in multiple myeloma - PubMed [pubmed.ncbi.nlm.nih.gov]
- 4. Degradation of NSC-281612 (4-[bis[2-[(methylsulfonyl)oxy]ethyl]amino]-2-methyl-benzaldehyde), an experimental antineoplastic agent: effects of pH, solvent composition, (SBE)7m-beta-CD, and HP-beta-CD on stability - PubMed [pubmed.ncbi.nlm.nih.gov]
- 5. [researchgate.net](https://www.researchgate.net) [[researchgate.net](https://www.researchgate.net)]
- 6. Degradation of NSC-281612 (4-[bis[2-[(methylsulfonyl)oxy]ethyl]amino]-2-methyl-benzaldehyde), an experimental antineoplastic agent: effects of pH, solvent composition, (SBE)7m-beta-CD, and HP-beta-CD on stability. | Semantic Scholar [[semanticscholar.org](https://www.semanticscholar.org)]
- 7. In vitro bioassays for anticancer drug screening: effects of cell concentration and other assay parameters on growth inhibitory activity - PubMed [pubmed.ncbi.nlm.nih.gov]
- 8. Quantitative and correlative biodistribution analysis of 89Zr-labeled mesoporous silica nanoparticles intravenously injected into tumor-bearing mice - Nanoscale (RSC Publishing) [pubs.rsc.org]
- 9. Impact of tumor-specific targeting on the biodistribution and efficacy of siRNA nanoparticles measured by multimodality in vivo imaging - PMC [[pmc.ncbi.nlm.nih.gov](https://pubmed.ncbi.nlm.nih.gov)]
- 10. [mdpi.com](https://www.mdpi.com) [[mdpi.com](https://www.mdpi.com)]
- 11. cdr.lib.unc.edu [cdr.lib.unc.edu]
- 12. [researchgate.net](https://www.researchgate.net) [[researchgate.net](https://www.researchgate.net)]
- 13. The In Vitro Anti-Tumor Activity of Phycocyanin against Non-Small Cell Lung Cancer Cells | MDPI [[mdpi.com](https://www.mdpi.com)]

- To cite this document: BenchChem. [Technical Support Center: Refining NSC12 Delivery Methods for Tumors]. BenchChem, [2026]. [Online PDF]. Available at: [<https://www.benchchem.com/product/b10752732/docs#technical-support-center-refining-nsc12-delivery-methods-for-tumors>]

Disclaimer & Data Validity:

The information provided in this document is for Research Use Only (RUO) and is strictly not intended for diagnostic or therapeutic procedures. While BenchChem strives to provide accurate protocols, we make no warranties, express or implied, regarding the fitness of this product for every specific experimental setup.

Technical Support: The protocols provided are for reference purposes. Unsure if this reagent suits your experiment?

Need Industrial/Bulk Grade? [Request Custom Synthesis Quote](#)

BenchChem

Our mission is to be the trusted global source of essential and advanced chemicals, empowering scientists and researchers to drive progress in science and industry.

Contact

Address: 3281 E Guasti Rd
Ontario, CA 91761, United States
Phone: (601) 213-4426
Email: info@benchchem.com

[Contact our Ph.D. Support Team for a compatibility check](#)