

# Protocol for Assessing (Z)-SU14813 Effects on Cell Migration

**Author:** BenchChem Technical Support Team. **Date:** April 2026

## Compound of Interest

Compound Name: (Z)-SU14813

Cat. No.: B10752453

[Get Quote](#)

Application Notes and Protocols for Researchers, Scientists, and Drug Development Professionals

## Introduction

**(Z)-SU14813** is a potent, multi-targeted receptor tyrosine kinase (RTK) inhibitor that has demonstrated significant anti-angiogenic and anti-tumor activity.<sup>[1][2]</sup> It effectively targets key signaling pathways involved in cell proliferation, survival, and migration by inhibiting the kinase activity of Vascular Endothelial Growth Factor Receptors (VEGFRs), Platelet-Derived Growth Factor Receptors (PDGFRs), and c-Kit.<sup>[1][2][3]</sup> Understanding the precise effects of **(Z)-SU14813** on cell migration is crucial for its development as a therapeutic agent, particularly in the context of oncology where cell motility is a key driver of metastasis.

These application notes provide a comprehensive overview and detailed protocols for assessing the in vitro effects of **(Z)-SU14813** on cell migration. The protocols for the wound healing (scratch) assay and the transwell migration assay are designed to yield robust and reproducible quantitative data, suitable for characterizing the inhibitory potential of this compound.

## Mechanism of Action and Signaling Pathways

**(Z)-SU14813** exerts its inhibitory effects on cell migration by blocking the phosphorylation and subsequent activation of several key receptor tyrosine kinases. The primary targets relevant to cell migration are VEGFR-2, PDGFR- $\beta$ , and c-Kit.<sup>[1][3]</sup>

### VEGFR-2 Signaling Pathway in Cell Migration

Vascular Endothelial Growth Factor Receptor 2 (VEGFR-2) is a critical mediator of angiogenesis, a process that heavily relies on the migration of endothelial cells. Upon binding of its ligand, VEGF, VEGFR-2 dimerizes and autophosphorylates, initiating a cascade of downstream signaling events. Key pathways include the activation of PLC $\gamma$ , protein kinase C (PKC), and the phosphatidylinositol 3-kinase (PI3K)/Akt pathway, all of which converge to regulate the cytoskeletal rearrangements and adhesive dynamics necessary for cell movement.

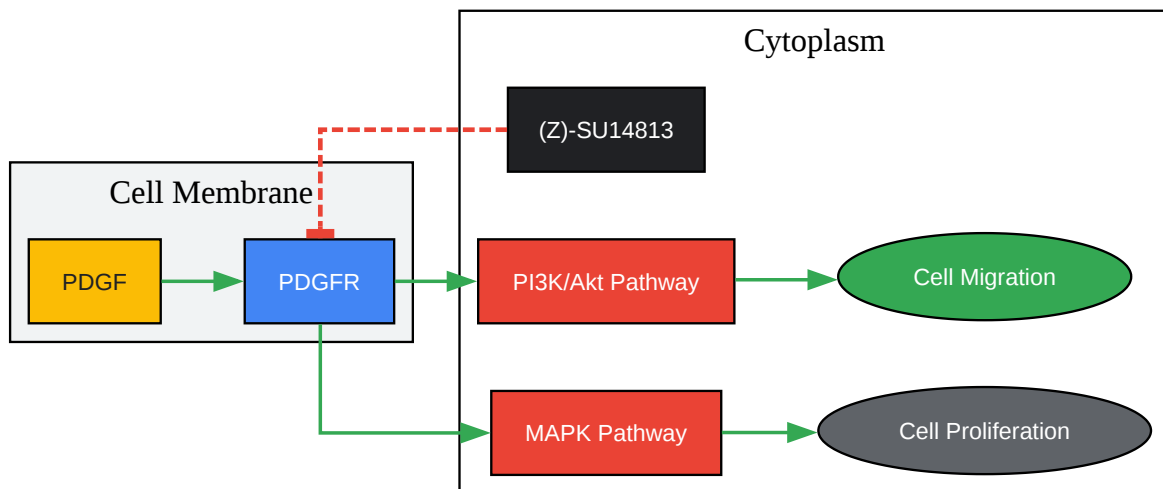
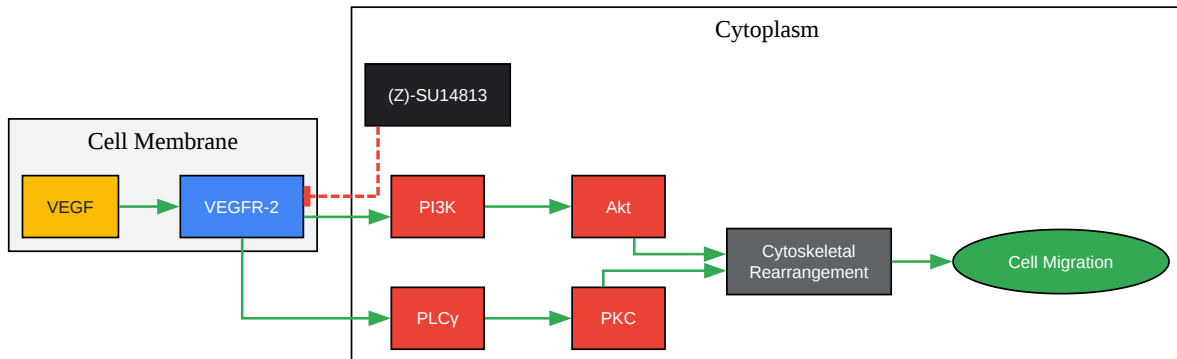

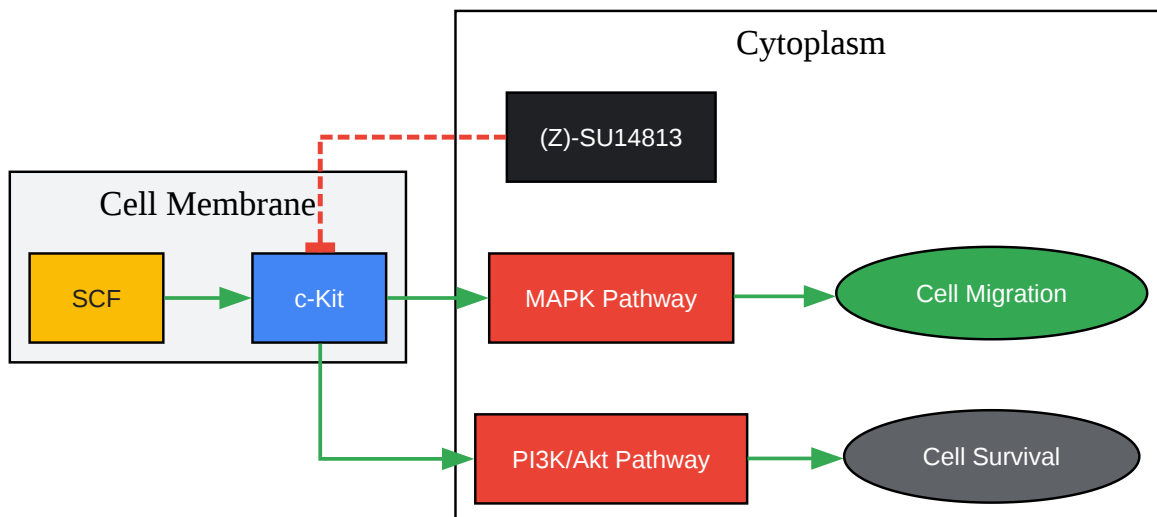

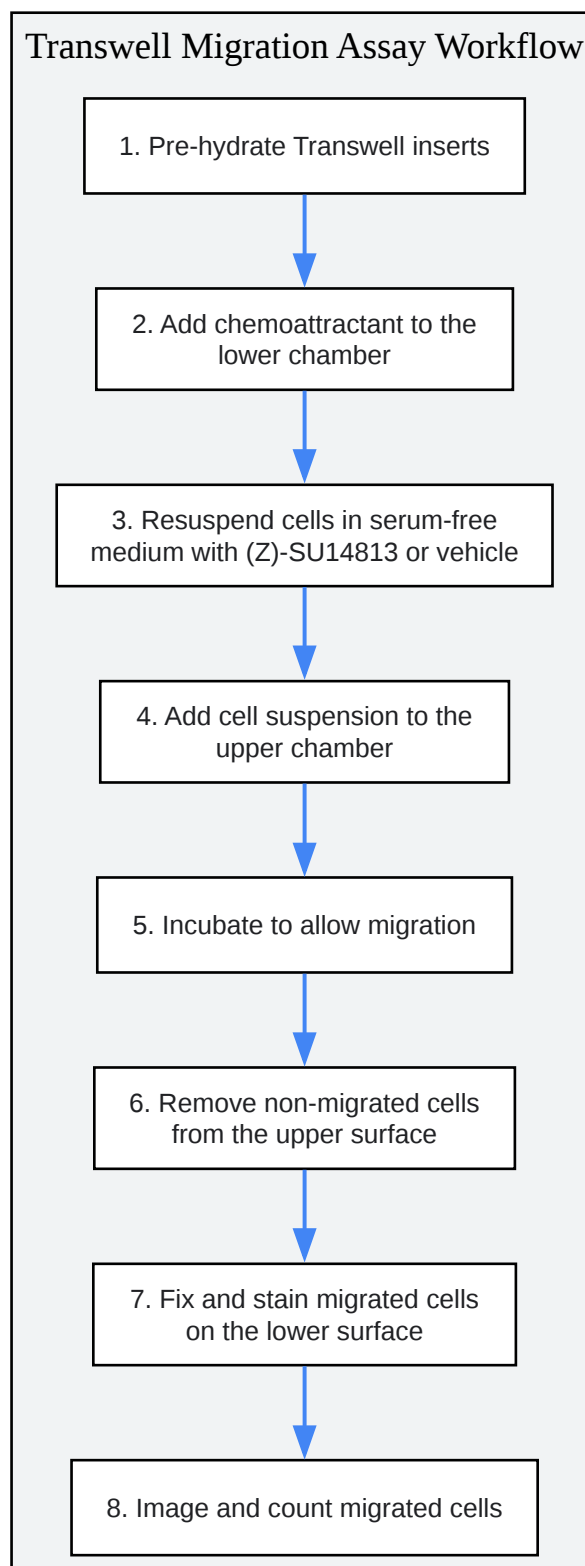
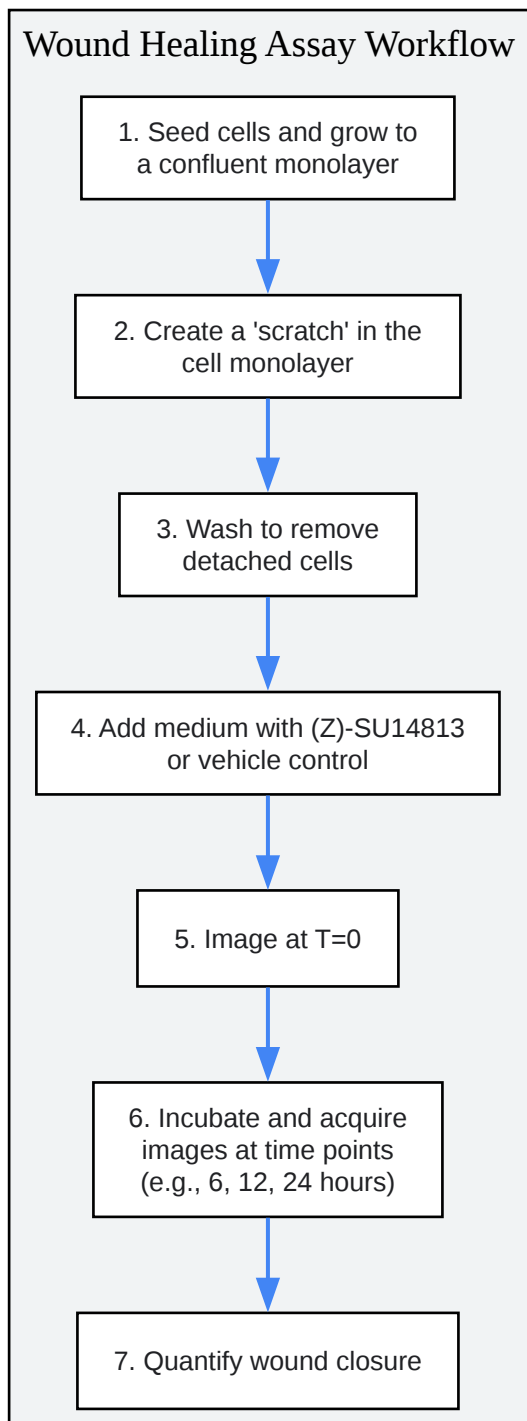

[Click to download full resolution via product page](#)

**Need Custom Synthesis?**

BenchChem offers custom synthesis for rare earth carbides and specific isotopic labeling.

Email: [info@benchchem.com](mailto:info@benchchem.com) or [Request Quote Online](#).

## References

- [1. aacrjournals.org \[aacrjournals.org\]](http://aacrjournals.org)
- [2. SU14813: a novel multiple receptor tyrosine kinase inhibitor with potent antiangiogenic and antitumor activity - PubMed \[pubmed.ncbi.nlm.nih.gov\]](#)
- [3. medchemexpress.com \[medchemexpress.com\]](http://medchemexpress.com)
- To cite this document: BenchChem. [Protocol for Assessing (Z)-SU14813 Effects on Cell Migration]. BenchChem, [2026]. [Online PDF]. Available at: [\[https://www.benchchem.com/product/b10752453/docs#protocol-for-assessing-z-su14813-effects-on-cell-migration\]](https://www.benchchem.com/product/b10752453/docs#protocol-for-assessing-z-su14813-effects-on-cell-migration)

---

**Disclaimer & Data Validity:**

The information provided in this document is for Research Use Only (RUO) and is strictly not intended for diagnostic or therapeutic procedures. While BenchChem strives to provide accurate protocols, we make no warranties, express or implied, regarding the fitness of this product for every specific experimental setup.

**Technical Support:** The protocols provided are for reference purposes. Unsure if this reagent suits your experiment?

**Need Industrial/Bulk Grade?** [Request Custom Synthesis Quote](#)

# BenchChem

Our mission is to be the trusted global source of essential and advanced chemicals, empowering scientists and researchers to drive progress in science and industry.

## Contact

Address: 3281 E Guasti Rd  
Ontario, CA 91761, United States  
Phone: (601) 213-4426  
Email: [info@benchchem.com](mailto:info@benchchem.com)

[Contact our Ph.D. Support Team for a compatibility check](#)