

NSC12 stability issues in long-term storage

Author: BenchChem Technical Support Team. **Date:** April 2026

Compound of Interest

Compound Name: NSC12
Cat. No.: B10752732

[Get Quote](#)

Technical Support Center: NSC12

This technical support center provides essential guidance for researchers, scientists, and drug development professionals on the stability of **NSC12** during long-term storage. The following troubleshooting guides and frequently asked questions (FAQs) address common issues to ensure the integrity and efficacy of **NSC12** in your experiments.

Frequently Asked Questions (FAQs)

Q1: What are the recommended long-term storage conditions for **NSC12**?

A1: Proper storage is critical for maintaining the stability of **NSC12**. For long-term storage, it is recommended to store **NSC12** as a solid (lyophilized powder) in a cool, dry, and dark place. Stock solutions should be stored at low temperatures to minimize degradation.

Q2: How long can I store **NSC12** stock solutions?

A2: The stability of **NSC12** in solution is dependent on the storage temperature. Based on general guidelines for small molecule inhibitors, stock solutions can be stored at -80°C for up to six months or at -20°C for up to one month. It is advisable to prepare fresh solutions for critical experiments whenever possible.

Q3: My **NSC12** solution appears cloudy or has visible precipitates. What should I do?

A3: Cloudiness or precipitation indicates that the compound may have come out of solution. This can be due to improper storage, solvent evaporation, or exceeding the solubility limit. Refer to the troubleshooting guide below for a step-by-step approach to address this issue.

Q4: Can I subject my **NSC12** stock solution to multiple freeze-thaw cycles?

A4: It is highly recommended to avoid multiple freeze-thaw cycles as this can lead to degradation of the compound and introduce variability in your experiments. Prepare small, single-use aliquots of your stock solution to maintain its integrity.

Q5: How can I check if my stored **NSC12** is still active?

A5: The bioactivity of **NSC12** can be assessed by performing a dose-response experiment in a relevant cell-based assay, such as an FGF-dependent cell proliferation assay. Compare the results obtained with the stored compound to those from a freshly prepared solution or a previously validated batch.

Troubleshooting Guides

Issue 1: Precipitation or Cloudiness in NSC12 Stock Solution

Possible Causes:

- The storage temperature was not low enough.
- The solvent has evaporated over time, increasing the compound's concentration beyond its solubility limit.
- The solution underwent multiple freeze-thaw cycles.

Troubleshooting Steps:

- Visual Inspection: Carefully inspect the vial for any visible particles or cloudiness.

- **Gentle Warming:** Warm the solution to room temperature or briefly in a 37°C water bath to see if the precipitate redissolves. Gentle vortexing can also aid in this process.
- **Solubility Check:** If the precipitate does not redissolve, it may indicate degradation or insolubility. Consider preparing a fresh stock solution.
- **Preventative Measures:** For future use, ensure you are aliquoting the stock solution into single-use vials and storing them at the recommended temperature.

Issue 2: Inconsistent or Reduced Efficacy in Experiments

Possible Causes:

- Degradation of **NSC12** due to improper long-term storage.
- Inaccurate concentration of the stock solution after prolonged storage.
- Repeated freeze-thaw cycles affecting the compound's stability.

Troubleshooting Steps:

- **Prepare Fresh Stock:** The most reliable solution is to prepare a fresh stock solution of **NSC12** from a solid compound.
- **Perform a Quality Control Check:** Run a simple in vitro assay to compare the activity of the old stock solution with the freshly prepared one. A significant shift in the IC50 value would indicate a loss of potency.
- **Analytical Validation:** For a more rigorous check, the concentration and purity of the stored **NSC12** solution can be verified using analytical techniques such as High-Performance Liquid Chromatography (HPLC).

Data Presentation

Table 1: Recommended Storage Conditions for **NSC12**

Form	Storage Temperature	Recommended Duration	Key Considerations
Solid (Powder)	-20°C to 4°C	> 1 year	Store in a desiccator to protect from moisture.
Stock Solution	-80°C	Up to 6 months	Aliquot into single-use vials to avoid freeze-thaw.
Stock Solution	-20°C	Up to 1 month	Suitable for shorter-term storage.

Experimental Protocols

Protocol 1: Stability Assessment of NSC12 using High-Performance Liquid Chromatography (HPLC)

This protocol outlines a general method to assess the stability of **NSC12** in a stock solution over time.

Materials:

- **NSC12** stock solution (e.g., 10 mM in DMSO)
- HPLC-grade DMSO (Dimethyl sulfoxide)
- HPLC-grade acetonitrile (ACN)
- HPLC-grade water
- Formic acid
- HPLC system with a C18 column and a UV detector

Methodology:

- Sample Preparation:

- At time zero (t=0), dilute the **NSC12** stock solution to a working concentration (e.g., 100 μ M) in a 50:50 mixture of acetonitrile and water with 0.1% formic acid.
- Store the stock solution under the desired long-term storage conditions (e.g., -20°C or -80°C).
- At subsequent time points (e.g., 1, 3, and 6 months), thaw an aliquot of the stored stock solution and prepare a sample for HPLC analysis in the same manner as the t=0 sample.
- HPLC Analysis:
 - Equilibrate the C18 column with the mobile phase (e.g., a gradient of acetonitrile and water with 0.1% formic acid).
 - Inject the prepared sample onto the HPLC system.
 - Monitor the elution of **NSC12** using a UV detector at a wavelength determined by a UV scan of the compound (typically around its absorbance maximum).
- Data Analysis:
 - Compare the peak area of the **NSC12** peak at each time point to the peak area at t=0.
 - A significant decrease in the peak area over time indicates degradation of the compound.
 - The appearance of new peaks may correspond to degradation products.

Visualizations

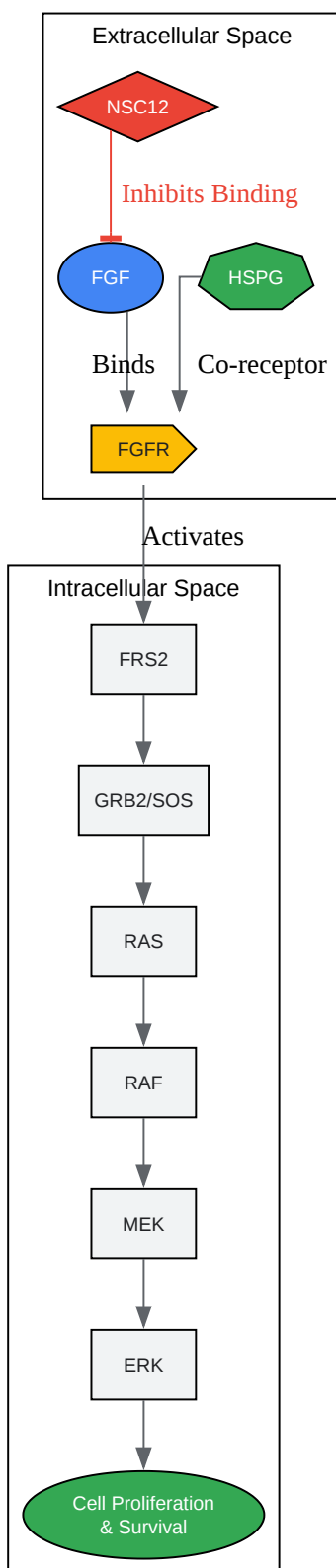

[Click to download full resolution via product page](#)

Caption: Mechanism of **NSC12** action in the FGF signaling pathway.

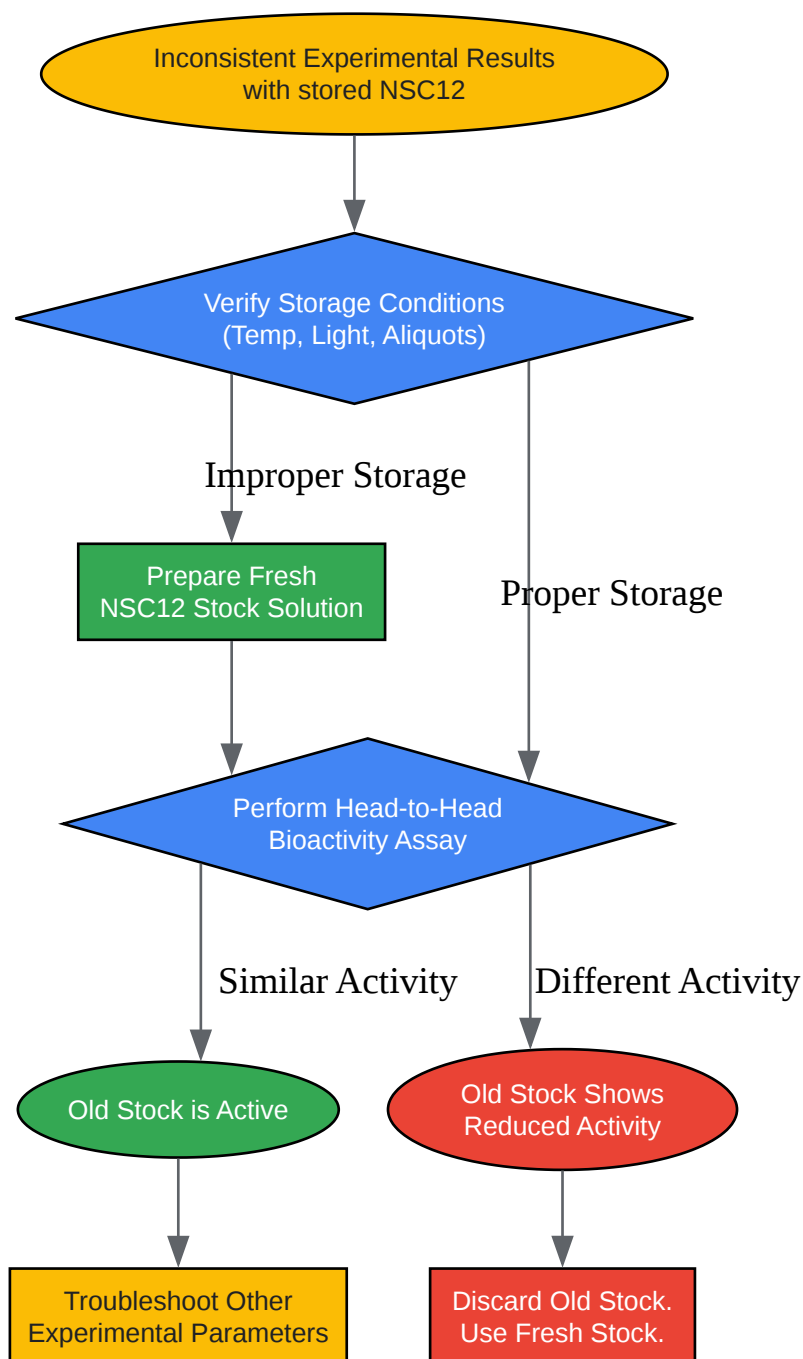

[Click to download full resolution via product page](#)

Caption: Troubleshooting workflow for inconsistent **NSC12** activity.

- To cite this document: BenchChem. [NSC12 stability issues in long-term storage]. BenchChem, [2026]. [Online PDF]. Available at: [\[https://www.benchchem.com/product/b10752732/docs#nsc12-stability-issues-in-long-term-storage\]](https://www.benchchem.com/product/b10752732/docs#nsc12-stability-issues-in-long-term-storage)

Disclaimer & Data Validity:

The information provided in this document is for Research Use Only (RUO) and is strictly not intended for diagnostic or therapeutic procedures. While BenchChem strives to provide accurate protocols, we make no warranties, express or implied, regarding the fitness of this product for every specific experimental setup.

Technical Support: The protocols provided are for reference purposes. Unsure if this reagent suits your experiment?

Need Industrial/Bulk Grade? [Request Custom Synthesis Quote](#)

BenchChem

Our mission is to be the trusted global source of essential and advanced chemicals, empowering scientists and researchers to drive progress in science and industry.

Contact

Address: 3281 E Guasti Rd
Ontario, CA 91761, United States
Phone: (601) 213-4426
Email: info@benchchem.com

[Contact our Ph.D. Support Team for a compatibility check](#)