

Independent Verification of GS-9822's Antiviral Potency: A Comparative Guide

Author: BenchChem Technical Support Team. **Date:** April 2026

Compound of Interest

Compound Name: GS-9822
Cat. No.: B10752815

[Get Quote](#)

For Researchers, Scientists, and Drug Development Professionals

This guide provides an objective comparison of the antiviral potency of **GS-9822**, a preclinical LEDGIN (Lens Epithelium-Derived Growth Factor/p75-integrase inhibitor), against other antiviral compounds. The data presented is collated from independent studies to offer a comprehensive overview for research and drug development professionals.

Executive Summary

GS-9822 is a potent inhibitor of HIV-1 replication, demonstrating low nanomolar activity against wild-type viruses.[1] Its mechanism of action involves the inhibition of the interaction between the HIV-1 integrase and the cellular cofactor LEDGF/p75, a critical step for viral integration and replication.[1] Comparative studies reveal that **GS-9822** is significantly more potent than the earlier generation LEDGIN, CX14442. This guide will delve into the quantitative data supporting these claims, provide detailed experimental methodologies for key assays, and visualize the relevant biological pathways and experimental workflows.

Comparative Antiviral Potency

The antiviral activity of **GS-9822** has been primarily evaluated and compared against CX14442 in cell-based assays. The following tables summarize the key quantitative data from these independent verification studies.

Table 1: In Vitro Antiviral Activity of **GS-9822** and Comparator Compounds against HIV-1

Compound	Virus Strain	Cell Line	EC50 (nM)	CC50 (µM)	Selectivity Index (SI = CC50/EC50)	Reference
GS-9822	HIV-1 IIIb	MT-4	6.1	1.8	295	[1]
GS-9822	HIV-1 NL4.3	MT-4	0.9	1.8	2000	[1]
CX14442	HIV-1 IIIb	MT-4	140	27	193	[1]
CX14442	HIV-1 NL4.3	MT-4	96	27	281	
BI-224436	HIV-1 (Lab Strains)	Various	<15	>90	>6000	
GSK3640254	HIV-1 (Clinical Isolates)	PBMC	9 (mean)	Not Reported	Not Reported	

Table 2: Inhibition of HIV-1 Integrase – LEDGF/p75 Interaction

Compound	Assay	IC50 (nM)	Reference
GS-9822	AlphaScreen	70	
CX14442	AlphaScreen	700	
BI-224436	LTR-cleavage assay	15	

Experimental Protocols

HIV-1 Replication Assay in MT-4 Cells

This assay is fundamental for determining the antiviral efficacy of a compound against HIV-1 in a relevant cell line.

Objective: To measure the concentration at which a compound inhibits HIV-1 replication by 50% (EC50).

Methodology:

- **Cell Culture:** MT-4 cells, a human T-cell line highly permissive to HIV-1, are cultured in RPMI 1640 medium supplemented with 10% fetal bovine serum, L-glutamine, and antibiotics.
- **Virus Infection:** MT-4 cells are infected with a laboratory-adapted strain of HIV-1 (e.g., IIIb or NL4.3) at a predetermined multiplicity of infection (MOI).
- **Compound Treatment:** Immediately after infection, the cells are plated in 96-well plates containing serial dilutions of the test compound (e.g., **GS-9822**, CX14442). Control wells with infected but untreated cells and uninfected cells are included.
- **Incubation:** The plates are incubated at 37°C in a 5% CO₂ atmosphere for 4-5 days, allowing for multiple rounds of viral replication.
- **Quantification of Viral Replication:** The extent of viral replication is determined by measuring a viral marker in the cell culture supernatant. Common methods include:
 - **p24 Antigen Capture ELISA:** This assay quantifies the amount of the viral core protein p24.
 - **Reverse Transcriptase (RT) Activity Assay:** This assay measures the activity of the viral enzyme reverse transcriptase.
- **Cytotoxicity Assay:** In parallel, the cytotoxic effect of the compound on uninfected MT-4 cells is determined using a cell viability assay (e.g., MTT or MTS assay) to calculate the 50% cytotoxic concentration (CC50).

- **Data Analysis:** The EC50 is calculated by plotting the percentage of inhibition of viral replication against the compound concentration and fitting the data to a dose-response curve. The Selectivity Index (SI) is then calculated as the ratio of CC50 to EC50.

AlphaScreen Assay for LEDGF/p75-Integrase Interaction

This biochemical assay directly measures the ability of a compound to inhibit the protein-protein interaction between HIV-1 integrase and its cellular cofactor LEDGF/p75.

Objective: To determine the concentration at which a compound inhibits the integrase-LEDGF/p75 interaction by 50% (IC50).

Methodology:

- **Reagents:**
 - Recombinant HIV-1 integrase (e.g., His-tagged).
 - Recombinant LEDGF/p75 (e.g., GST-tagged).
 - AlphaScreen Donor beads (e.g., Streptavidin-coated).
 - AlphaScreen Acceptor beads (e.g., anti-GST antibody-coated).
 - Assay buffer.
- **Assay Principle:** The His-tagged integrase is captured by Nickel chelate-coated Acceptor beads, and the GST-tagged LEDGF/p75 is captured by anti-GST Acceptor beads. When the two proteins interact, the Donor and Acceptor beads are brought into close proximity. Upon excitation at 680 nm, the Donor beads release singlet oxygen, which excites the Acceptor beads, resulting in a chemiluminescent signal at 520-620 nm. An inhibitor of the interaction will prevent this proximity and reduce the signal.
- **Procedure:**
 - Serial dilutions of the test compound are prepared in the assay buffer.

- A mixture of the recombinant integrase and LEDGF/p75 proteins is added to the wells of a 384-well plate.
- The test compound is added to the wells.
- The AlphaScreen Donor and Acceptor beads are added.
- The plate is incubated in the dark at room temperature to allow the interaction to reach equilibrium.
- Signal Detection: The chemiluminescent signal is read using an AlphaScreen-compatible plate reader.
- Data Analysis: The IC50 value is determined by plotting the percentage of inhibition of the signal against the compound concentration and fitting the data to a dose-response curve.

Visualizations

Mechanism of Action: Inhibition of LEDGF/p75-Integrase Interaction

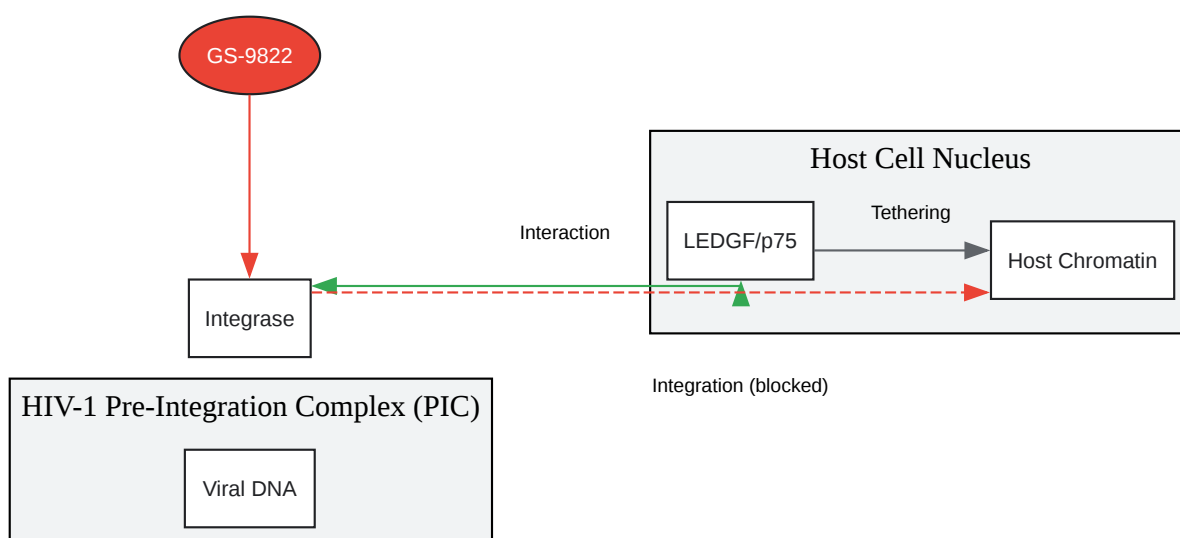

[Click to download full resolution via product page](#)

Caption: **GS-9822** binds to HIV-1 integrase, blocking its interaction with the host protein LEDGF/p75.

Experimental Workflow: HIV-1 Replication Assay

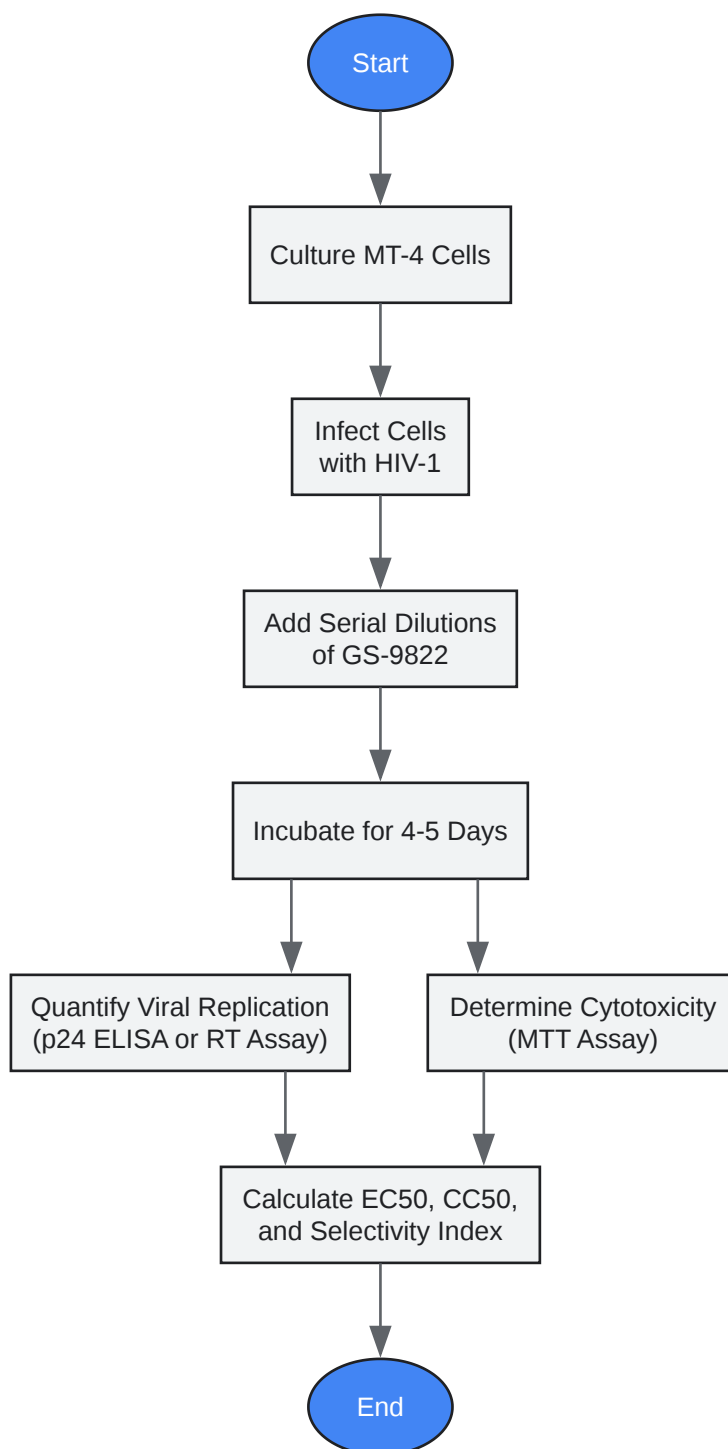

[Click to download full resolution via product page](#)

Caption: Workflow for determining the antiviral efficacy of **GS-9822** using an MT-4 cell-based assay.

Logical Relationship: Comparison of LEDGINs

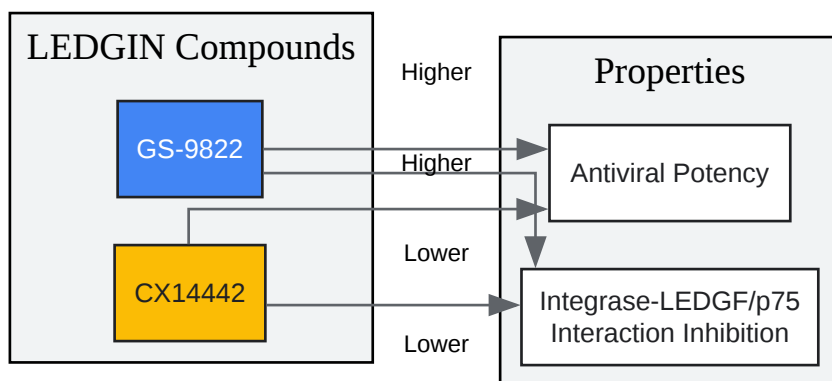

[Click to download full resolution via product page](#)

Caption: **GS-9822** demonstrates higher potency than CX14442 in both antiviral activity and target engagement.

Need Custom Synthesis?

BenchChem offers custom synthesis for rare earth carbides and specific isotopic labeling.

Email: info@benchchem.com or [Request Quote Online](#).

References

- 1. GS-9822, a Preclinical LEDGIN Candidate, Displays a Block-and-Lock Phenotype in Cell Culture - PMC [[pmc.ncbi.nlm.nih.gov](https://pubmed.ncbi.nlm.nih.gov/)]
- To cite this document: BenchChem. [Independent Verification of GS-9822's Antiviral Potency: A Comparative Guide]. BenchChem, [2026]. [Online PDF]. Available at: [<https://www.benchchem.com/product/b10752815/docs#independent-verification-of-gs-9822-s-antiviral-potency-a-comparative-guide>]

Disclaimer & Data Validity:

The information provided in this document is for Research Use Only (RUO) and is strictly not intended for diagnostic or therapeutic procedures. While BenchChem strives to provide accurate protocols, we make no warranties, express or implied, regarding the fitness of this product for every specific experimental setup.

Technical Support: The protocols provided are for reference purposes. Unsure if this reagent suits your experiment?

Need Industrial/Bulk Grade? [Request Custom Synthesis Quote](#)

BenchChem

Our mission is to be the trusted global source of essential and advanced chemicals, empowering scientists and researchers to drive progress in science and industry.

Contact

Address: 3281 E Guasti Rd
Ontario, CA 91761, United States
Phone: (601) 213-4426
Email: info@benchchem.com

[Contact our Ph.D. Support Team for a compatibility check](#)