

# Application Notes and Protocols for (Z)-SU14813 Experiments

**Author:** BenchChem Technical Support Team. **Date:** April 2026

## Compound of Interest

Compound Name: (Z)-SU14813

Cat. No.: B10752453

[Get Quote](#)

For Researchers, Scientists, and Drug Development Professionals

## Introduction

**(Z)-SU14813** is a potent, multi-targeted receptor tyrosine kinase (RTK) inhibitor with significant anti-angiogenic and anti-tumor properties.<sup>[1][2]</sup> It exerts its effects by targeting several key RTKs involved in cancer progression, including Vascular Endothelial Growth Factor Receptors (VEGFRs), Platelet-Derived Growth Factor Receptors (PDGFRs), Stem Cell Factor Receptor (KIT), and FMS-like Tyrosine Kinase 3 (FLT3).<sup>[1][2][3][4]</sup> This document provides detailed application notes and protocols for conducting cell culture experiments with **(Z)-SU14813** to evaluate its efficacy and mechanism of action in various cancer cell lines.

## Mechanism of Action and Signaling Pathways

**(Z)-SU14813** functions by binding to the ATP-binding site of the aforementioned RTKs, thereby inhibiting their kinase activity and blocking downstream signaling cascades that are crucial for cell proliferation, survival, migration, and angiogenesis.<sup>[1][2]</sup> The simultaneous inhibition of these multiple pathways makes **(Z)-SU14813** an effective agent against a broad range of malignancies.<sup>[1][4]</sup>

Below is a diagram illustrating the primary signaling pathways inhibited by **(Z)-SU14813**.

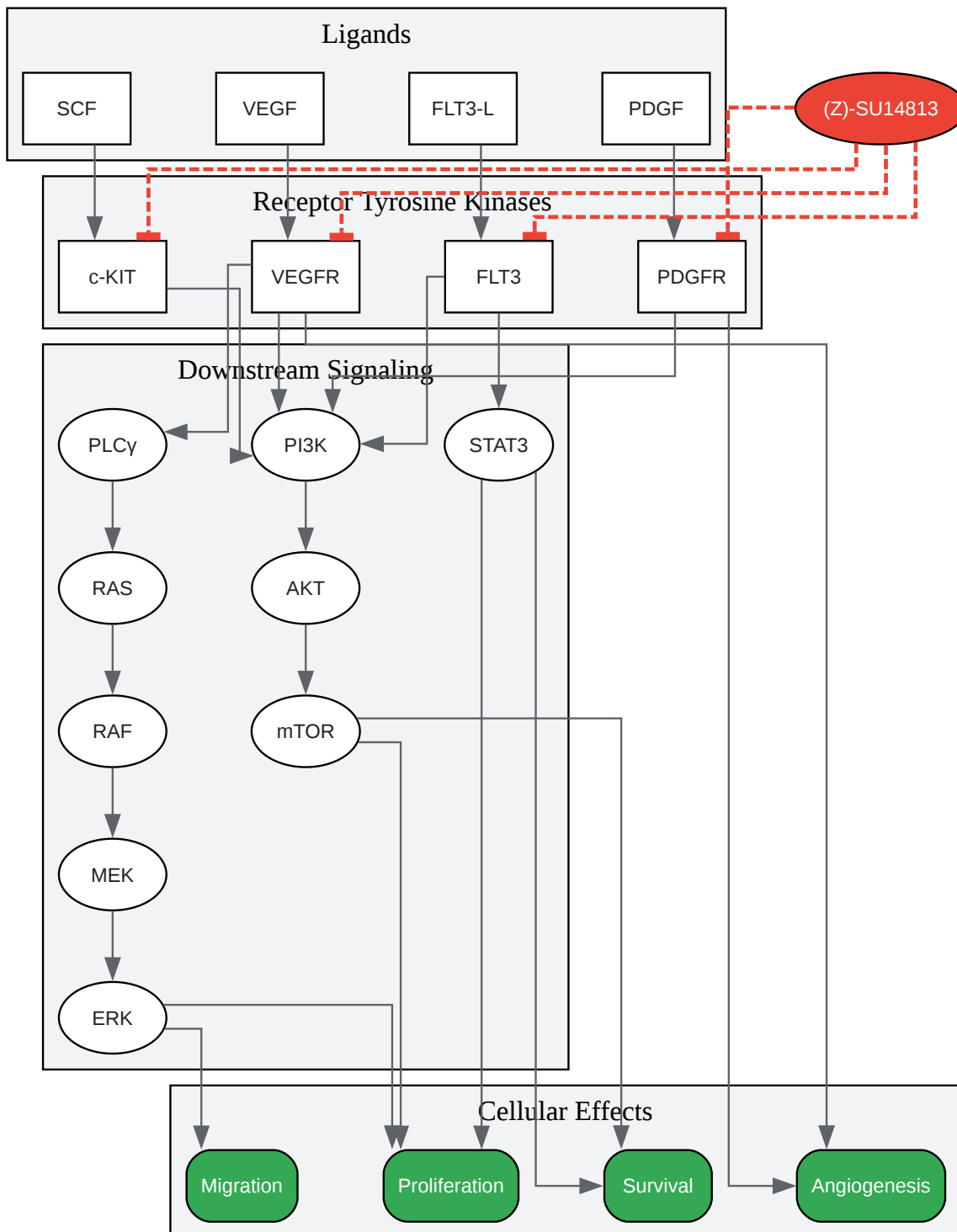

[Click to download full resolution via product page](#)

Caption: **(Z)-SU14813** inhibits VEGFR, PDGFR, KIT, and FLT3 signaling pathways.

## Quantitative Data Summary

The inhibitory activity of **(Z)-SU14813** has been quantified in various biochemical and cellular assays. The following tables summarize the half-maximal inhibitory concentrations (IC50) of **(Z)-SU14813** against its primary targets and in different cell lines.

Table 1: Biochemical IC50 Values of **(Z)-SU14813** Against Target Kinases

Target Kinase	IC50 (nM)
VEGFR-1	2[5]
VEGFR-2	50[5]
PDGFR $\beta$	4[5]
KIT	15[5]

Table 2: Cellular IC50 Values of **(Z)-SU14813**

Cell Line	Assay Type	IC50 (nM)
Porcine Aortic Endothelial Cells (VEGFR-2 overexpressing)	Receptor Phosphorylation	5.2[3][5]
Porcine Aortic Endothelial Cells (PDGFR $\beta$ overexpressing)	Receptor Phosphorylation	9.9[3][5]
Porcine Aortic Endothelial Cells (KIT overexpressing)	Receptor Phosphorylation	11.2[3][5]
U-118MG (Glioblastoma)	Growth Inhibition	50 - 100[5]
Human Umbilical Vein Endothelial Cells (HUVEC)	VEGF-stimulated survival	~20

## Recommended Cell Culture Conditions

Successful experiments with **(Z)-SU14813** rely on optimal cell culture conditions. Below is a summary of recommended media and handling for commonly used cell lines in SU14813 research.

Table 3: Summary of Cell Culture Conditions

Cell Line	Organism	Tissue of Origin	Recommended Medium
MV-4-11	Human	Peripheral Blood (B-myelomonocytic leukemia)	IMDM + 10% FBS + 1% P/S[1][2]
U-118 MG	Human	Brain (Glioblastoma)	DMEM + 10% FBS + 4.5 g/L Glucose + 4 mM L-Glutamine + 1.5 g/L NaHCO <sub>3</sub> + 1.0 mM Sodium pyruvate[6][7]
NIH 3T3	Mouse	Embryo (Fibroblast)	DMEM + 10% Bovine Calf Serum[8][9]
HUVEC	Human	Umbilical Vein (Endothelial)	EGM-2 or F12K + 10% FBS + supplements (e.g., heparin, ECGS)[10]
Colo205	Human	Colon (Adenocarcinoma)	RPMI-1640 + 10% FBS + 1% P/S[2][11][12]
786-O	Human	Kidney (Renal Cell Adenocarcinoma)	RPMI-1640 + 10% FBS + 1% P/S[13][14][15]
C6 Rat Glioma	Rat	Brain (Glioma)	Ham's F-12K + 15% Horse Serum + 2.5% FBS[16][17]

## Experimental Protocols

### Preparation of (Z)-SU14813 Stock Solution

- Reconstitution: (Z)-SU14813 is soluble in DMSO.[18] To prepare a stock solution, dissolve the compound in fresh, anhydrous DMSO to a concentration of 10 mM.

- **Storage:** Aliquot the stock solution into smaller volumes to avoid repeated freeze-thaw cycles and store at -20°C or -80°C for long-term use. When preparing working solutions, dilute the stock solution in the appropriate cell culture medium to the desired final concentration immediately before use. The final DMSO concentration in the culture medium should typically be kept below 0.1% (v/v) to avoid solvent-induced cytotoxicity.

## Cell Viability and Cytotoxicity Assays

The SRB assay is a colorimetric method used to determine cell number based on the measurement of total cellular protein content.[10][19]



[Click to download full resolution via product page](#)

Caption: Workflow for the Sulforhodamine B (SRB) assay.

Protocol:

- **Cell Plating:** Seed cells into 96-well plates at an appropriate density (e.g., 5,000-10,000 cells/well) in 100 μL of complete culture medium and incubate for 24 hours to allow for cell attachment.
- **Compound Treatment:** Prepare serial dilutions of **(Z)-SU14813** in culture medium. Replace the existing medium with 100 μL of the medium containing the desired concentrations of the compound. Include vehicle-only controls (medium with the same concentration of DMSO as the highest drug concentration).
- **Incubation:** Incubate the plates for the desired exposure time (e.g., 48 or 72 hours) at 37°C in a humidified 5% CO<sub>2</sub> incubator.
- **Cell Fixation:** Gently add 50 μL of cold 10% (w/v) trichloroacetic acid (TCA) to each well and incubate at 4°C for 1 hour to fix the cells.

- **Washing:** Carefully discard the supernatant and wash the wells five times with slow-running tap water. Remove excess water by tapping the plate on a paper towel and allow the plates to air dry completely.
- **SRB Staining:** Add 100  $\mu\text{L}$  of 0.4% (w/v) SRB solution in 1% acetic acid to each well and incubate at room temperature for 30 minutes.
- **Removal of Unbound Dye:** Quickly wash the wells four times with 200  $\mu\text{L}$  of 1% (v/v) acetic acid to remove the unbound SRB dye. Allow the plates to air dry.
- **Solubilization of Bound Dye:** Add 200  $\mu\text{L}$  of 10 mM Tris base solution (pH 10.5) to each well and place the plate on a shaker for 5-10 minutes to solubilize the protein-bound dye.[16][20]
- **Absorbance Measurement:** Measure the optical density (OD) at a wavelength of 510-565 nm using a microplate reader.[16][20]

The MTT assay is a colorimetric assay for assessing cell metabolic activity, which is indicative of cell viability.[17] This protocol is adapted for assessing the effect of **(Z)-SU14813** on VEGF-stimulated HUVEC survival.

#### Protocol:

- **Cell Culture and Seeding:** Culture HUVECs in EGM-2 medium. Seed the cells into a 96-well plate at a density of 5,000-10,000 cells per well in 100  $\mu\text{L}$  of complete medium and incubate for 24 hours.
- **Serum Starvation:** After 24 hours, replace the medium with 100  $\mu\text{L}$  of serum-free or low-serum (e.g., 1% FBS) medium and incubate for 12-24 hours.
- **Treatment:** Prepare serial dilutions of **(Z)-SU14813** in serum-free medium. Add 50  $\mu\text{L}$  of the SU14813 dilutions to the respective wells. After 45 minutes, add 50  $\mu\text{L}$  of a 2X VEGF solution (e.g., 40 ng/mL for a final concentration of 20 ng/mL) to stimulate the cells. Include appropriate controls (cells with vehicle and VEGF, cells with vehicle only).
- **Incubation:** Incubate the plate for 48-72 hours at 37°C.

- MTT Addition: Add 10  $\mu\text{L}$  of MTT reagent (5 mg/mL in PBS) to each well and incubate for 3-4 hours at 37°C until formazan crystals are visible.
- Solubilization: Aspirate the medium containing MTT and add 150  $\mu\text{L}$  of DMSO to each well to dissolve the formazan crystals. Shake the plate gently for 5 minutes.
- Data Acquisition: Measure the absorbance at 570 nm using a microplate reader.

## Anchorage-Independent Growth Assay (Soft Agar Assay)

This assay measures the ability of cells to grow in a semi-solid medium, a hallmark of cellular transformation. [21][22]



[Click to download full resolution via product page](#)

Caption: Workflow for the soft agar anchorage-independent growth assay.

Protocol:

- Prepare Base Layer: Prepare a 0.6-0.8% agar solution in complete culture medium. Pipette 2 mL of this solution into each well of a 6-well plate and allow it to solidify at room temperature in a sterile hood.
- Prepare Top Layer with Cells: Prepare a 0.7% low-melting-point agarose solution and cool it to 40°C in a water bath. Harvest cells by trypsinization and resuspend them in complete culture medium. Mix the cell suspension with the cooled agarose solution to achieve a final agarose concentration of 0.3-0.4% and the desired cell density (e.g., 5,000-10,000 cells/well). Include the desired concentrations of **(Z)-SU14813** in this top layer.

- **Plating:** Gently pipette 1.5 mL of the cell/agarose mixture on top of the solidified base layer in each well.
- **Incubation:** Allow the top layer to solidify at room temperature, then transfer the plates to a 37°C, 5% CO<sub>2</sub> incubator. Incubate for 2-4 weeks, or until colonies are visible. Feed the cells every 3-4 days by adding 200-300 µL of fresh medium containing the appropriate concentration of **(Z)-SU14813** on top of the agar.
- **Colony Staining and Counting:** After the incubation period, stain the colonies by adding 0.5 mL of 0.005% Crystal Violet solution to each well and incubating for 1-2 hours. Count the number of colonies in each well using a microscope.

## Conclusion

These application notes and protocols provide a comprehensive guide for researchers utilizing **(Z)-SU14813** in cell culture experiments. By following these guidelines for cell handling, experimental setup, and data acquisition, scientists can effectively investigate the anti-cancer properties of this multi-targeted RTK inhibitor. Adherence to these standardized methods will facilitate the generation of reliable and reproducible data, contributing to a deeper understanding of the therapeutic potential of **(Z)-SU14813**.

### *Need Custom Synthesis?*

*BenchChem offers custom synthesis for rare earth carbides and specific isotopic labeling.*

*Email: [info@benchchem.com](mailto:info@benchchem.com) or [Request Quote Online](#).*

## References

- [1. nih3t3.com](http://nih3t3.com) [nih3t3.com]
- [2. innov-research.com](http://innov-research.com) [innov-research.com]
- [3. aacrjournals.org](http://aacrjournals.org) [aacrjournals.org]
- [4. SU14813: a novel multiple receptor tyrosine kinase inhibitor with potent antiangiogenic and antitumor activity - PubMed](https://pubmed.ncbi.nlm.nih.gov) [pubmed.ncbi.nlm.nih.gov]
- [5. medchemexpress.com](http://medchemexpress.com) [medchemexpress.com]

- [6. COLO 205 Cell Complete Medium - Elabscience® \[elabscience.com\]](#)
- [7. Continuous culture of rat C6 glioma in serum-free medium - PubMed \[pubmed.ncbi.nlm.nih.gov\]](#)
- [8. bcrj.org.br \[bcrj.org.br\]](#)
- [9. cellbiolabs.com \[cellbiolabs.com\]](#)
- [10. HUVEC Cell Culture Guide \[absin.net\]](#)
- [11. atcc.org \[atcc.org\]](#)
- [12. resources.amsbio.com \[resources.amsbio.com\]](#)
- [13. Human 786-o Clear Cell Renal Cell Carcinoma Cells \(786-o\) | CSI427Hu11 | Homo sapiens \(Human\) CLOUD-CLONE CORP.\(CCC\) \[cloud-clone.com\]](#)
- [14. 786-O Cell Line - Creative Biogene \[creative-biogene.com\]](#)
- [15. 786-0 Renal cancer cell line-derived exosomes promote 786-0 cell migration and invasion in vitro - PMC \[pmc.ncbi.nlm.nih.gov\]](#)
- [16. atcc.org \[atcc.org\]](#)
- [17. C6-Luc Rat Glioma Cells - Creative Biolabs \[neuros.creative-biolabs.com\]](#)
- [18. C6. Culture Collections \[culturecollections.org.uk\]](#)
- [19. COLO 205. Culture Collections \[culturecollections.org.uk\]](#)
- [20. researchgate.net \[researchgate.net\]](#)
- [21. cff.org \[cff.org\]](#)
- [22. researchgate.net \[researchgate.net\]](#)
- [To cite this document: BenchChem. \[Application Notes and Protocols for \(Z\)-SU14813 Experiments\]. BenchChem, \[2026\]. \[Online PDF\]. Available at: \[https://www.benchchem.com/product/b10752453/docs#application-notes-and-protocols-for-z-su14813-experiments\]](#)

---

**Disclaimer & Data Validity:**

The information provided in this document is for Research Use Only (RUO) and is strictly not intended for diagnostic or therapeutic procedures. While BenchChem strives to provide accurate protocols, we make no warranties, express or implied, regarding the fitness of this product for every specific experimental setup.

**Technical Support:** The protocols provided are for reference purposes. Unsure if this reagent suits your experiment?

**Need Industrial/Bulk Grade?** [Request Custom Synthesis Quote](#)

## BenchChem

Our mission is to be the trusted global source of essential and advanced chemicals, empowering scientists and researchers to drive progress in science and industry.

### Contact

Address: 3281 E Guasti Rd  
Ontario, CA 91761, United States  
Phone: (601) 213-4426  
Email: [info@benchchem.com](mailto:info@benchchem.com)

[Contact our Ph.D. Support Team for a compatibility check](#)