

# Application Notes and Protocols for AlphaScreen Assay of GS-9822

**Author:** BenchChem Technical Support Team. **Date:** April 2026

## Compound of Interest

Compound Name: GS-9822  
Cat. No.: B10752815

[Get Quote](#)

For Researchers, Scientists, and Drug Development Professionals

## Abstract

This document provides a detailed protocol for performing an AlphaScreen (Amplified Luminescent Proximity Homogeneous Assay) to quantitatively assess the inhibitory activity of **GS-9822** on the interaction between HIV-1 integrase (IN) and the lens epithelium-derived growth factor (LEDGF)/p75. **GS-9822** is a potent preclinical HIV-1 inhibitor that disrupts this critical protein-protein interaction, thereby impairing viral replication.<sup>[1][2][3][4][5]</sup> The AlphaScreen technology offers a sensitive, high-throughput method for identifying and characterizing inhibitors of this interaction.

## Introduction

The integration of the viral genome into the host cell's DNA is a crucial step in the HIV-1 replication cycle, mediated by the viral enzyme integrase (IN). The cellular cofactor LEDGF/p75 plays a pivotal role in this process by tethering the pre-integration complex to the host chromatin, thereby guiding the integration process. The interaction between IN and LEDGF/p75 is therefore a prime target for antiretroviral drug development.

**GS-9822** is a small molecule inhibitor that potently disrupts the IN-LEDGF/p75 interaction. The AlphaScreen assay is a bead-based, non-radioactive, homogeneous proximity assay ideal for studying biomolecular interactions. It relies on the transfer of singlet oxygen from a donor bead to an acceptor bead when they are brought into close proximity by the interacting molecules of interest. Inhibition of the interaction by a compound like **GS-9822** leads to a decrease in the AlphaScreen signal.

## Signaling Pathway

The interaction between HIV-1 integrase and LEDGF/p75 is a key step in the integration of the viral DNA into the host genome. LEDGF/p75 acts as a cellular tether, guiding the integrase-viral DNA complex to transcriptionally active regions of the host chromatin.

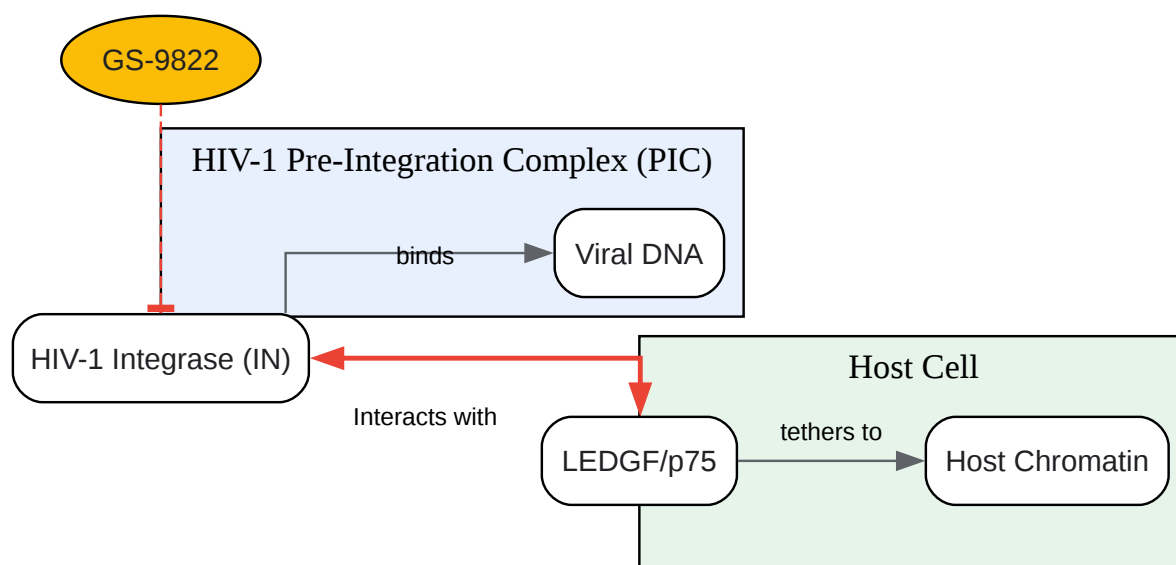

[Click to download full resolution via product page](#)

Caption: HIV-1 Integrase-LEDGF/p75 Interaction Pathway and Inhibition by **GS-9822**.

## Experimental Workflow

The AlphaScreen assay for **GS-9822** involves the use of His-tagged HIV-1 integrase and Flag-tagged LEDGF/p75. Nickel chelate-coated donor beads bind to the His-tagged integrase, while anti-Flag antibody-coated acceptor beads bind to the Flag-tagged LEDGF/p75. When the two

proteins interact, the beads are brought into proximity, generating a signal. **GS-9822** competes with this interaction, leading to a reduction in the signal.

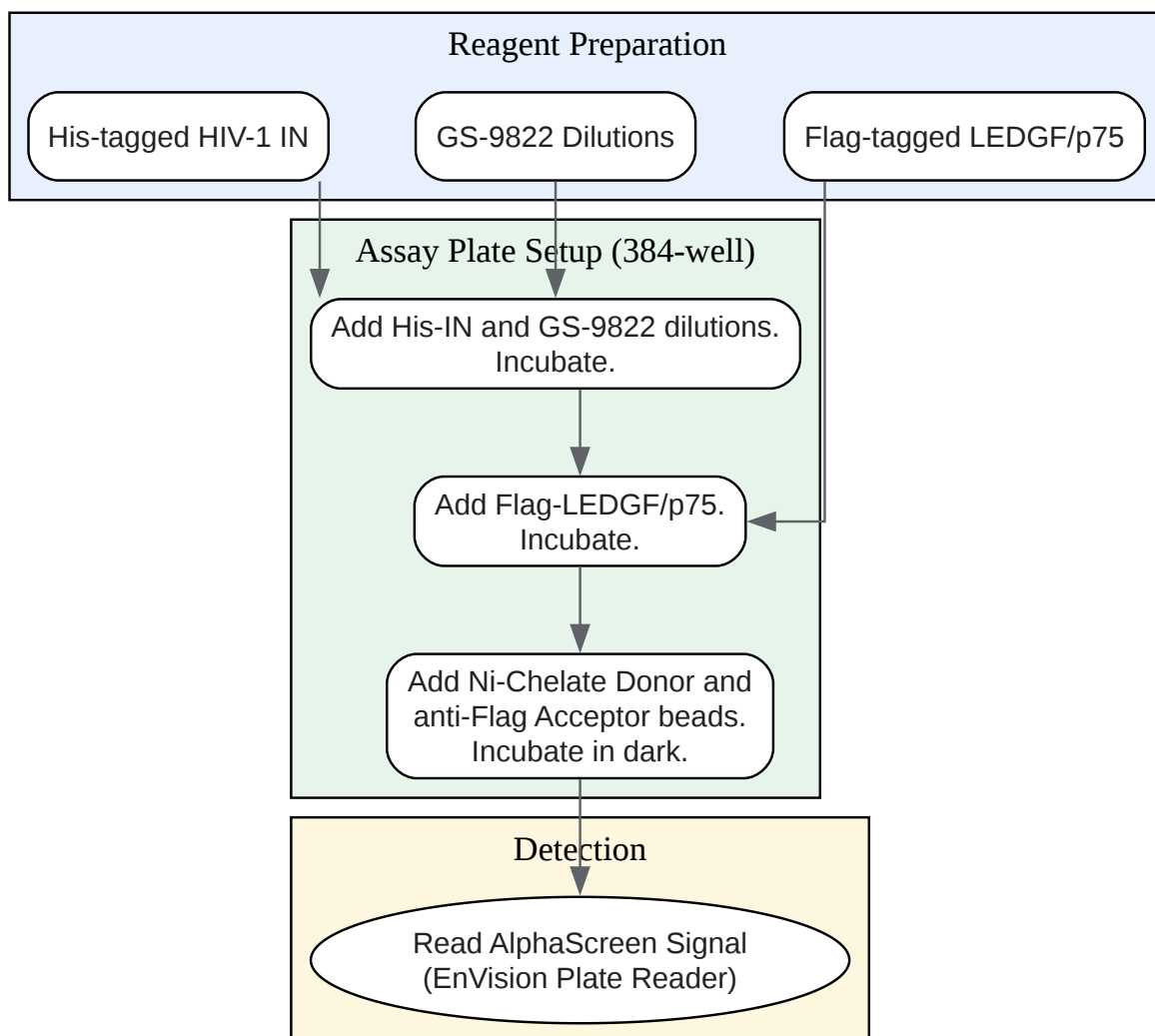

[Click to download full resolution via product page](#)

Caption: AlphaScreen Assay Workflow for **GS-9822**.

## Experimental Protocols

### Materials and Reagents

- Proteins:

- His6-tagged HIV-1 integrase (His-IN)
- Flag-tagged LEDGF/p75 (Flag-p75)
- Compound:
  - **GS-9822**
- AlphaScreen Beads:
  - Nickel Chelate Donor Beads (PerkinElmer)
  - Anti-Flag Acceptor Beads (PerkinElmer)
- Assay Buffer:
  - 25 mM Tris/HCl, pH 7.3
  - 150 mM NaCl
  - 1 mM MgCl<sub>2</sub>
  - 0.1% Tween 20
  - 0.1% Bovine Serum Albumin (BSA)
- Plates:
  - 384-well white opaque microtiter plates (e.g., OptiPlate-384)
- Equipment:
  - EnVision Plate Reader (PerkinElmer) or equivalent with AlphaScreen capabilities
  - Multichannel pipettes
  - Plate shaker

## Assay Protocol

This protocol is adapted from the method described for evaluating **GS-9822**'s inhibition of the IN-LEDGF/p75 interaction.

- Compound Preparation:
  - Prepare a serial dilution of **GS-9822** in assay buffer. The final concentrations in the assay will typically range from 0.001 to 500  $\mu\text{M}$ .
- Protein and Compound Incubation:
  - In a 384-well plate, add 5  $\mu\text{L}$  of His-IN solution to each well to achieve a final concentration of 50 nM.
  - Add 5  $\mu\text{L}$  of the various **GS-9822** dilutions to the respective wells. For control wells (maximum signal), add 5  $\mu\text{L}$  of assay buffer without the compound.
  - Incubate the plate for 30 minutes at 4°C.
- Addition of Second Protein:
  - Add 5  $\mu\text{L}$  of Flag-tagged LEDGF/p75 solution to each well to achieve a final concentration of 100 nM.
  - Incubate the plate for an additional 1 hour at 4°C.
- Addition of AlphaScreen Beads:
  - Prepare a 1:100 dilution of a mixture of Nickel Chelate Donor Beads and anti-FLAG coated Acceptor Beads in assay buffer.
  - Add 10  $\mu\text{L}$  of the bead mixture to each well.
  - Incubate the plate for 3 hours at 30°C, ensuring the plate is protected from light.
- Signal Detection:
  - Read the plate on an EnVision plate reader in AlphaScreen mode.

## Data Analysis

- The raw AlphaScreen counts are collected for each well.
- The percentage of inhibition is calculated for each concentration of **GS-9822** using the following formula:
  - Signal\_compound: Signal in the presence of **GS-9822**.
  - Signal\_background: Signal in the absence of one of the interacting proteins (e.g., no Flag-p75).
  - Signal\_max: Signal in the absence of **GS-9822**.
- The IC50 value (the concentration of inhibitor that reduces the signal by 50%) is determined by plotting the percentage of inhibition against the logarithm of the **GS-9822** concentration and fitting the data to a sigmoidal dose-response curve using software such as GraphPad Prism.

## Data Presentation

The inhibitory activity of **GS-9822** on the HIV-1 integrase-LEDGF/p75 interaction, as determined by the AlphaScreen assay, is summarized below.

Compound	Target Interaction	Assay Type	IC50 (μM)	Reference
GS-9822	HIV-1 Integrase - LEDGF/p75	AlphaScreen	0.07	

## Conclusion

The AlphaScreen assay provides a robust and sensitive platform for quantifying the inhibitory potency of compounds like **GS-9822** against the HIV-1 integrase-LEDGF/p75 interaction. This detailed protocol and the accompanying information will aid researchers in the successful implementation of this assay for drug discovery and development efforts targeting this critical step in the HIV-1 life cycle.

**Need Custom Synthesis?**

BenchChem offers custom synthesis for rare earth carbides and specific isotopic labeling.

Email: [info@benchchem.com](mailto:info@benchchem.com) or [Request Quote Online](#).

## References

- 1. Integrase, LEDGF/p75 and HIV replication - PubMed [[pubmed.ncbi.nlm.nih.gov](https://pubmed.ncbi.nlm.nih.gov)]
- 2. Characterization of the HIV-1 integrase chromatin- and LEDGF/p75-binding abilities by mutagenic analysis within the catalytic core domain of integrase - PMC [[pubmed.ncbi.nlm.nih.gov](https://pubmed.ncbi.nlm.nih.gov)]
- 3. [revvity.com](https://revvity.com) [[revvity.com](https://revvity.com)]
- 4. [researchgate.net](https://researchgate.net) [[researchgate.net](https://researchgate.net)]
- 5. GS-9822, a Preclinical LEDGIN Candidate, Displays a Block-and-Lock Phenotype in Cell Culture - PMC [[pubmed.ncbi.nlm.nih.gov](https://pubmed.ncbi.nlm.nih.gov)]
- To cite this document: BenchChem. [Application Notes and Protocols for AlphaScreen Assay of GS-9822]. BenchChem, [2026]. [Online PDF]. Available at: [<https://www.benchchem.com/product/b10752815/docs#application-notes-and-protocols-for-alphascreen-assay-of-gs-9822>]

---

**Disclaimer & Data Validity:**

The information provided in this document is for Research Use Only (RUO) and is strictly not intended for diagnostic or therapeutic procedures. While BenchChem strives to provide accurate protocols, we make no warranties, express or implied, regarding the fitness of this product for every specific experimental setup.

**Technical Support:** The protocols provided are for reference purposes. Unsure if this reagent suits your experiment?

**Need Industrial/Bulk Grade?** [Request Custom Synthesis Quote](#)

# BenchChem

Our mission is to be the trusted global source of essential and advanced chemicals, empowering scientists and researchers to drive progress in science and industry.

## Contact

Address: 3281 E Guasti Rd

Ontario, CA 91761, United States

Phone: (601) 213-4426

Email: [info@benchchem.com](mailto:info@benchchem.com)

[Contact our Ph.D. Support Team for a compatibility check](#)