

A Comparative Guide to FGFR Inhibition: NSC12 vs. PD173074

Author: BenchChem Technical Support Team. **Date:** April 2026

Compound of Interest

Compound Name: NSC12
Cat. No.: B10752620

Get Quote

In the landscape of targeted cancer therapy, the Fibroblast Growth Factor Receptor (FGFR) signaling pathway has emerged as a critical focus for drug development. Dysregulation of this pathway is implicated in the progression of numerous malignancies, driving tumor growth, angiogenesis, and metastasis. This guide provides a detailed comparison of two distinct FGFR inhibitors, **NSC12** and PD173074, offering insights into their mechanisms of action, inhibitory profiles, and experimental validation for researchers and drug development professionals.

Mechanism of Action: A Tale of Two Inhibitors

NSC12 and PD173074 employ fundamentally different strategies to disrupt FGFR signaling. PD173074 is a classic small-molecule tyrosine kinase inhibitor (TKI) that acts intracellularly. It is an ATP-competitive inhibitor, binding to the kinase domain of FGFRs and preventing the autophosphorylation necessary for downstream signal transduction.[1][2] In contrast, **NSC12** functions as an extracellular "pan-FGF trap".[3][4][5] It directly binds to various Fibroblast Growth Factors (FGFs), preventing them from interacting with and activating their cognate receptors on the cell surface.[3][4]

Comparative Inhibitory Profile

The differing mechanisms of **NSC12** and PD173074 are reflected in their inhibitory activities and specificities. The following tables summarize the available quantitative data for each compound.

Table 1: Inhibitory Activity of PD173074

Target	IC50 Value	Ki Value	Notes
FGFR1	21.5 - 25 nM[1][6][7]	~40 nM[6]	Potent, ATP-competitive inhibition. [1]
FGFR3	5 nM[1][8]	-	Highly potent inhibition.
VEGFR2	~100 - 200 nM[6][7][8]	-	Also shows activity against this key angiogenic receptor.
PDGFR	>17,600 nM[2][8]	-	High selectivity over PDGFR.[6]
c-Src	>19,800 nM[2][8]	-	High selectivity over c-Src.[6]
EGFR, InsR, MEK, PKC	>50,000 nM[8]	-	Negligible activity against these kinases.

 Table 2: Inhibitory Activity of **NSC12**

Target Interaction	ID50/Kd Value	Notes
FGF2 binding to FGFR1	ID50 ~30 μ M[3]	Inhibits the protein-protein interaction.
Binding to FGF2	-	Functions as an FGF2 trap.[4]
Binding to other FGFs (FGF3, FGF4, FGF6, FGF8, FGF16, FGF18, FGF20, FGF22)	Kd ~16 - 120 μ M[3]	Demonstrates broad, pan-FGF binding activity.

Functional Consequences of FGFR Inhibition

Both inhibitors have demonstrated significant anti-tumor effects in preclinical studies.

PD173074 has been shown to:

- Inhibit proliferation and induce apoptosis in various cancer cell lines, including breast and gastric cancer.[7][9]
- Block angiogenesis both in vitro and in vivo.[8]
- Suppress tumor growth in xenograft models of small cell lung cancer and head and neck cancer.[8][10]
- Inhibit downstream signaling through the MAPK and Akt pathways.[6]

NSC12 has been shown to:

- Inhibit the proliferation of FGF-dependent murine and human cancer cell lines.[3]
- Reduce tumor growth, angiogenesis, and metastasis in vivo through both parenteral and oral administration.[3]
- Inhibit the phosphorylation of FGFR1, FGFR2, FGFR3, and FGFR4.[3]
- Induce apoptosis in lung cancer cells through the downregulation of c-Myc and an increase in oxidative stress.[11]

Experimental Protocols

Detailed methodologies are crucial for the replication and validation of experimental findings. Below are representative protocols for assays commonly used to evaluate these inhibitors.

Kinase Inhibition Assay (for PD173074)

This assay determines the concentration of an inhibitor required to block 50% of a target kinase's activity (IC50).

- Reagents: Purified recombinant FGFR1 or FGFR3 kinase domain, ATP, a suitable peptide substrate, and PD173074.
- Procedure: a. Prepare a serial dilution of PD173074 in a suitable buffer (e.g., DMSO). b. In a microplate, combine the FGFR enzyme, the peptide substrate, and the various concentrations of PD173074. c. Initiate the kinase reaction by adding a solution containing ATP. d. Incubate the plate at a controlled temperature (e.g., 30°C) for a specified time (e.g., 60 minutes). e. Terminate the reaction and quantify the amount of phosphorylated substrate. This can be done using various methods, such as radiometric assays (with [γ - 32 P]ATP) or luminescence-based assays that measure the remaining ATP. f. Plot the percentage of kinase activity against the logarithm of the inhibitor concentration and fit the data to a sigmoidal dose-response curve to determine the IC₅₀ value.

Cell Proliferation (MTT) Assay (for NSC12 and PD173074)

This colorimetric assay measures the metabolic activity of cells, which is an indicator of cell viability and proliferation.

- Cell Culture: Plate cancer cells (e.g., FGF-dependent KATO III cells) in 96-well plates and allow them to adhere overnight.[3]
- Treatment: Treat the cells with a range of concentrations of **NSC12** or PD173074. Include appropriate controls (e.g., vehicle-only). For **NSC12**, cells can be co-treated with an FGF ligand (e.g., 30 ng/ml FGF2) to stimulate proliferation.[3]
- Incubation: Incubate the cells for a period that allows for measurable changes in proliferation (e.g., 72 hours).[3]
- MTT Addition: Add MTT (3-(4,5-dimethylthiazol-2-yl)-2,5-diphenyltetrazolium bromide) solution to each well and incubate for 2-4 hours. Viable cells with active metabolism will reduce the yellow MTT to purple formazan crystals.
- Solubilization: Add a solubilization solution (e.g., DMSO or a solution of SDS in HCl) to dissolve the formazan crystals.

- Measurement: Read the absorbance of the wells at a wavelength of 570-595 nm using a microplate reader.[3] The absorbance is directly proportional to the number of viable cells.

Western Blotting for FGFR Phosphorylation

This technique is used to assess the phosphorylation status of FGFR and downstream signaling proteins.

- Cell Lysis: Treat cells with the inhibitor for a specified time, then lyse the cells in RIPA buffer supplemented with protease and phosphatase inhibitors.
- Protein Quantification: Determine the protein concentration of each lysate using a BCA or Bradford assay.
- Electrophoresis: Separate equal amounts of protein from each sample by SDS-PAGE.
- Transfer: Transfer the separated proteins to a PVDF or nitrocellulose membrane.
- Blocking: Block the membrane with a suitable blocking buffer (e.g., 5% non-fat milk or BSA in TBST) to prevent non-specific antibody binding.
- Antibody Incubation: Incubate the membrane with a primary antibody specific for phosphorylated FGFR (p-FGFR) or other phosphorylated downstream targets (e.g., p-ERK, p-Akt). Subsequently, incubate with a horseradish peroxidase (HRP)-conjugated secondary antibody.
- Detection: Detect the protein bands using an enhanced chemiluminescence (ECL) substrate and an imaging system. Use an antibody against total FGFR or a housekeeping protein (e.g., GAPDH or β -actin) as a loading control.

Visualizing the Mechanisms and Workflows

To further clarify the concepts discussed, the following diagrams illustrate the FGFR signaling pathway and a comparative experimental workflow.

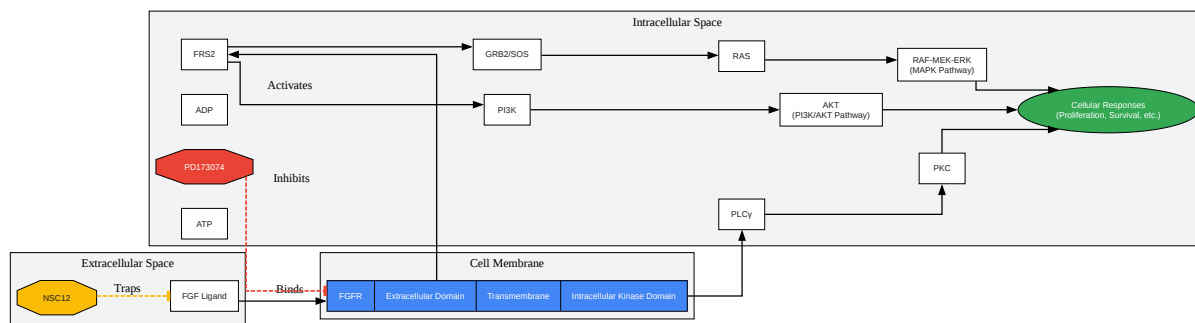

[Click to download full resolution via product page](#)

Caption: FGFR signaling pathway and points of inhibition.

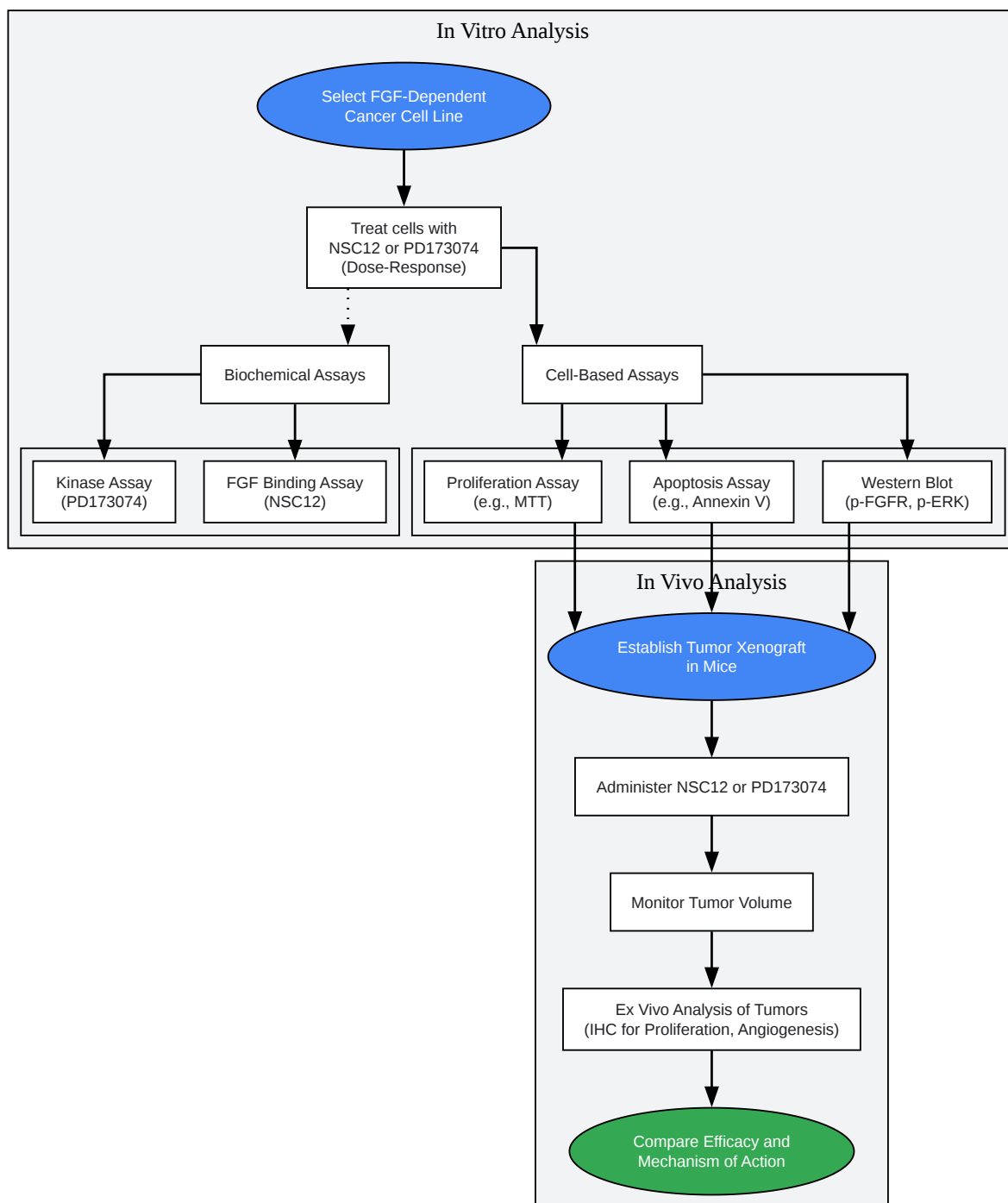

[Click to download full resolution via product page](#)

Caption: Comparative experimental workflow for evaluating FGFR inhibitors.

Conclusion

NSC12 and PD173074 represent two distinct and compelling approaches to targeting the FGFR signaling axis. PD173074 is a potent, selective, intracellular ATP-competitive inhibitor of the FGFR kinase domain, while **NSC12** is an extracellular pan-FGF trap that prevents ligand-receptor engagement. The choice between these or similar inhibitors will depend on the specific biological context, including the expression of various FGF ligands and potential resistance mechanisms to ATP-competitive TKIs. The data and protocols presented in this guide provide a framework for researchers to design and interpret experiments aimed at further elucidating the therapeutic potential of these compounds in FGFR-driven cancers.

Need Custom Synthesis?

BenchChem offers custom synthesis for rare earth carbides and specific isotopic labeling.

Email: info@benchchem.com or [Request Quote Online](#).

References

- [1. stemcell.com](https://www.stemcell.com) [stemcell.com]
- [2. benchchem.com](https://www.benchchem.com) [benchchem.com]
- [3. selleckchem.com](https://www.selleckchem.com) [selleckchem.com]
- [4. medchemexpress.com](https://www.medchemexpress.com) [medchemexpress.com]
- [5. adooq.com](https://www.adooq.com) [adooq.com]
- [6. medchemexpress.com](https://www.medchemexpress.com) [medchemexpress.com]
- [7. selleckchem.com](https://www.selleckchem.com) [selleckchem.com]
- [8. rndsystems.com](https://www.rndsystems.com) [rndsystems.com]
- [9. Inhibition of FGFR signaling by PD173074 improves antitumor immunity and impairs breast cancer metastasis - PubMed](https://pubmed.ncbi.nlm.nih.gov/) [pubmed.ncbi.nlm.nih.gov]
- [10. Inhibition of Fibroblasts Reduced Head and Neck Cancer Growth by Targeting FGFR - PMC](https://pubmed.ncbi.nlm.nih.gov/) [pmc.ncbi.nlm.nih.gov]
- [11. Inhibition of the FGF/FGFR System Induces Apoptosis in Lung Cancer Cells via c-Myc Downregulation and Oxidative Stress - PMC](https://pubmed.ncbi.nlm.nih.gov/) [pmc.ncbi.nlm.nih.gov]

- To cite this document: BenchChem. [A Comparative Guide to FGFR Inhibition: NSC12 vs. PD173074]. BenchChem, [2026]. [Online PDF]. Available at: [<https://www.benchchem.com/product/b10752620/docs#a-comparative-guide-to-fgfr-inhibition-nsc12-vs-pd173074>]

Disclaimer & Data Validity:

The information provided in this document is for Research Use Only (RUO) and is strictly not intended for diagnostic or therapeutic procedures. While BenchChem strives to provide accurate protocols, we make no warranties, express or implied, regarding the fitness of this product for every specific experimental setup.

Technical Support: The protocols provided are for reference purposes. Unsure if this reagent suits your experiment?

Need Industrial/Bulk Grade? [Request Custom Synthesis Quote](#)

BenchChem

Our mission is to be the trusted global source of essential and advanced chemicals, empowering scientists and researchers to drive progress in science and industry.

Contact

Address: 3281 E Guasti Rd

Ontario, CA 91761, United States

Phone: (601) 213-4426

Email: info@benchchem.com

[Contact our Ph.D. Support Team for a compatibility check](#)