

# Technical Support Center: (E)-5-Decen-1-yl Acetate Synthesis

**Author:** BenchChem Technical Support Team. **Date:** May 2026

## Compound of Interest

Compound Name: (E)-5-Decen-1-yl acetate

CAS No.: 38421-90-8

Cat. No.: B107312

[Get Quote](#)

Welcome to the technical support center for the synthesis and purification of **(E)-5-Decen-1-yl acetate**. This resource provides detailed troubleshooting guides and frequently asked questions (FAQs) to help researchers, scientists, and drug development professionals identify and resolve common impurities encountered during synthesis.

## Frequently Asked Questions (FAQs)

Q1: What are the most common impurities found in the synthesis of **(E)-5-Decen-1-yl acetate**?

A1: The most prevalent impurities typically arise from the synthetic route used, most commonly the Wittig reaction. These include:

- (Z)-5-Decen-1-yl acetate: The geometric isomer of the target compound. Its formation is highly dependent on the reaction conditions and the type of Wittig reagent used.
- Triphenylphosphine oxide (TPPO): A common and often difficult-to-remove byproduct of the Wittig reaction.[\[1\]](#)[\[2\]](#)

- **Unreacted Starting Materials:** Residual amounts of the starting aldehyde (e.g., pentanal) or the phosphonium salt.
- **Solvent Residues:** Traces of solvents used during the reaction or work-up, such as tetrahydrofuran (THF), diethyl ether, or ethyl acetate.[3]
- **Side-products from the Ylide Generation:** Impurities can arise from side reactions during the formation of the phosphorus ylide, especially if the base is not sufficiently strong or if moisture is present.[2]

Q2: My primary impurity is the (Z)-isomer. How can I increase the E/Z ratio in my reaction and separate the isomers?

A2: Achieving high (E)-selectivity is a common challenge.

- **Reaction Control:** To favor the (E)-isomer, a "stabilized" Wittig ylide is typically used. If using a non-stabilized or semi-stabilized ylide, the Schlosser modification of the Wittig reaction can be employed, which involves treating the intermediate betaine with phenyllithium at low temperatures to equilibrate it to the more stable threo-betaine, leading to the (E)-alkene upon decomposition.[4][5]
- **Purification:** The most effective method for separating (E) and (Z) isomers is silica gel column chromatography.[3] Due to the small difference in polarity, a high-efficiency silica gel and a carefully optimized non-polar eluent system are required. Argentation chromatography (silica gel impregnated with silver nitrate) can also be highly effective, as the silver ions interact differently with the  $\pi$ -bonds of the cis and trans isomers.

Q3: How do I effectively remove triphenylphosphine oxide (TPPO) from my product?

A3: TPPO is notoriously difficult to remove due to its polarity, which is often similar to that of the desired product. Several methods can be employed:

- **Crystallization:** If your product is a solid, TPPO can sometimes be removed by recrystallization from a non-polar solvent like hexane or a hexane/ether mixture, as TPPO is less soluble. However, **(E)-5-Decen-1-yl acetate** is a liquid.

- Column Chromatography: Careful column chromatography on silica gel is the most common method.<sup>[3]</sup> A gradient elution, starting with a non-polar solvent (like hexane) and gradually increasing the polarity (with ethyl acetate or ether), can effectively separate the less polar product from the more polar TPPO.
- Precipitation: TPPO can be precipitated from a solution in diethyl ether by adding pentane or hexane and cooling to a low temperature (e.g., 0 °C or -20 °C). The precipitated TPPO can then be filtered off.
- Extraction: Converting TPPO to a water-soluble salt by reaction with MgBr<sub>2</sub> or CaCl<sub>2</sub> has been reported, allowing it to be removed via aqueous extraction.

Q4: What analytical techniques are recommended to confirm the purity and isomeric ratio of my final product?

A4: A combination of techniques is recommended for full characterization:

- Gas Chromatography-Mass Spectrometry (GC-MS): This is the primary method to determine the overall purity and identify volatile impurities. The isomeric ratio (E/Z) can also be determined if the isomers are well-resolved on the GC column.
- Nuclear Magnetic Resonance (NMR) Spectroscopy:
  - <sup>1</sup>H NMR: Provides crucial information about the structure. The coupling constant (J-value) of the vinylic protons is diagnostic for the stereochemistry. For the (E)-isomer, a large coupling constant (typically 12-18 Hz) is expected, while the (Z)-isomer shows a smaller coupling constant (6-12 Hz).
  - <sup>13</sup>C NMR: Confirms the carbon skeleton and the presence of all expected carbon atoms.
- Fourier-Transform Infrared Spectroscopy (FTIR): Can confirm the presence of key functional groups, such as the C=C double bond (around 1650-1670 cm<sup>-1</sup>) and the ester carbonyl group (around 1740 cm<sup>-1</sup>). For trans-alkenes, an out-of-plane C-H bending band is often observed around 960-970 cm<sup>-1</sup>.

## Troubleshooting Guides

This section addresses specific issues you might encounter during the synthesis and purification process.

## Issue 1: Low Yield of (E)-5-Decen-1-yl Acetate

Potential Cause	Recommended Solution
Inefficient Ylide Formation	Ensure all glassware is oven-dried and the reaction is performed under an inert atmosphere (e.g., Argon or Nitrogen) to prevent moisture from quenching the strong base.[3] Use a sufficiently strong base (e.g., n-BuLi, NaH, or NaHMDS) to fully deprotonate the phosphonium salt.[1][2]
Poor Reactivity of Aldehyde	Check the purity of the aldehyde starting material. Aldehydes can oxidize to carboxylic acids on storage, which will not participate in the Wittig reaction.
Suboptimal Reaction Temperature	For non-stabilized ylides, reactions are often run at low temperatures to improve selectivity and yield. For stabilized ylides, higher temperatures may be required. Optimize the temperature based on the specific ylide used.
Product Loss During Work-up	Ensure complete extraction of the product from the aqueous phase by using an appropriate organic solvent and performing multiple extractions.[3] Avoid overly aggressive washing with acidic or basic solutions if the product is sensitive.

## Issue 2: Poor E/Z Selectivity

Reaction Conditions Favoring (Z)-Isomer	Solutions to Increase (E)-Isomer Formation
Use of non-stabilized ylides in aprotic, salt-free conditions.	Employ stabilized ylides (containing an electron-withdrawing group adjacent to the carbanion), which thermodynamically favor the formation of the (E)-alkene.[6]
Presence of lithium salts from ylide generation (e.g., from n-BuLi).	Use sodium-based (e.g., NaH, NaHMDS) or potassium-based bases to generate the ylide, as these "salt-free" conditions often favor Z-selectivity but their absence is key in other modifications. The Schlosser modification is the most direct route to the (E)-isomer from non-stabilized ylides.[5]

## Experimental Protocols

### Protocol 1: Purification by Silica Gel Column Chromatography

This protocol describes a standard method for purifying crude **(E)-5-Decen-1-yl acetate** to separate it from the (Z)-isomer and TPPO.

- Column Preparation:
  - Select a glass column of appropriate size for the amount of crude material (typically a 50:1 to 100:1 ratio of silica gel to crude product by weight).
  - Prepare a slurry of silica gel (230-400 mesh) in the initial eluent (e.g., 98:2 Hexane:Ethyl Acetate).
  - Wet-pack the column with the slurry, ensuring no air bubbles are trapped. Add a small layer of sand on top of the silica bed.
- Sample Loading:
  - Dissolve the crude product in a minimal amount of a non-polar solvent (e.g., hexane or dichloromethane).

- Alternatively, adsorb the crude product onto a small amount of silica gel by dissolving it in a volatile solvent, adding the silica, and evaporating the solvent under reduced pressure.
- Carefully load the concentrated sample or the dry-loaded silica onto the top of the column.
- Elution and Fraction Collection:
  - Begin eluting the column with a low-polarity solvent system (e.g., 98:2 Hexane:Ethyl Acetate).[3] The less polar (E)-isomer will typically elute before the slightly more polar (Z)-isomer, followed by the much more polar TPPO.
  - Collect fractions of a consistent volume (e.g., 10-20 mL).
  - Monitor the elution process using Thin Layer Chromatography (TLC) to identify which fractions contain the desired product.
- Product Recovery:
  - Combine the pure fractions containing the (E)-isomer.
  - Remove the solvent using a rotary evaporator to yield the purified **(E)-5-Decen-1-yl acetate** as an oil.[3]

## Protocol 2: Purity and Isomer Ratio Analysis by GC-MS

- Sample Preparation: Prepare a dilute solution of the purified product (approx. 1 mg/mL) in a volatile solvent like hexane or ethyl acetate.
- GC Method:
  - Column: Use a standard non-polar capillary column (e.g., DB-5ms, HP-5ms).
  - Injection: Inject 1  $\mu$ L of the sample solution.
  - Temperature Program: Start at a low temperature (e.g., 60 °C), hold for 1-2 minutes, then ramp the temperature at a controlled rate (e.g., 10 °C/min) to a final temperature (e.g., 250 °C) and hold for several minutes.

- Carrier Gas: Helium at a constant flow rate.
- MS Method:
  - Ionization: Electron Ionization (EI) at 70 eV.
  - Scan Range: Scan a mass-to-charge (m/z) range of approximately 40-400 amu.
- Data Analysis:
  - Integrate the peak areas in the total ion chromatogram (TIC) to determine the relative percentage of each component, which corresponds to the purity.
  - Identify the peaks corresponding to the (E) and (Z) isomers based on their retention times. Calculate the isomeric ratio from their respective peak areas.
  - Confirm the identity of the product and any impurities by comparing their mass spectra to a library database (e.g., NIST).[7]

## Visualizations

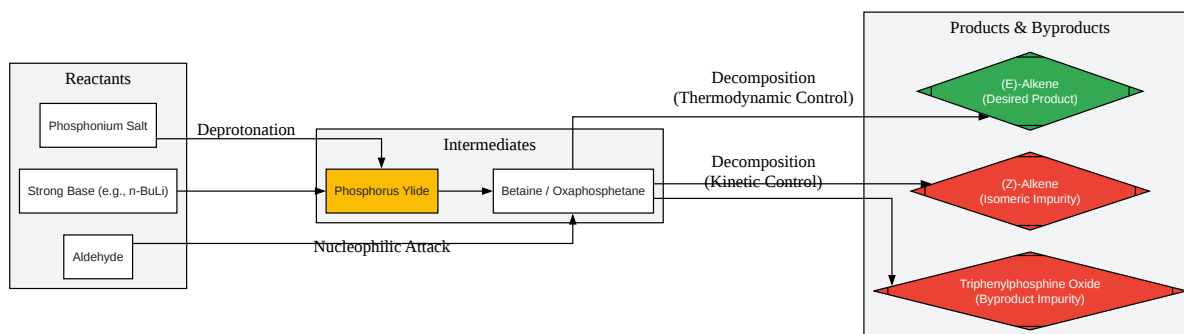

[Click to download full resolution via product page](#)

Caption: Simplified pathway of the Wittig reaction showing the formation of desired (E)-alkene and key impurities.

Caption: Logical workflow for troubleshooting and purifying crude **(E)-5-Decen-1-yl acetate**.

### Need Custom Synthesis?

BenchChem offers custom synthesis for rare earth carbides and specific isotopic labeling.

Email: [info@benchchem.com](mailto:info@benchchem.com) or [Request Quote Online](#).

## References

- [1. youtube.com \[youtube.com\]](https://www.youtube.com)
- [2. masterorganicchemistry.com \[masterorganicchemistry.com\]](https://www.masterorganicchemistry.com)
- [3. Organic Syntheses Procedure \[orgsyn.org\]](https://www.orgsyn.org)
- [4. Wittig reaction - Wikipedia \[en.wikipedia.org\]](https://en.wikipedia.org)
- [5. chem.libretexts.org \[chem.libretexts.org\]](https://chem.libretexts.org)
- [6. Wittig Reaction \[organic-chemistry.org\]](https://www.organic-chemistry.org)
- [7. 5-Decen-1-ol, acetate, \(E\)- \[webbook.nist.gov\]](https://webbook.nist.gov)
- To cite this document: BenchChem. [Technical Support Center: (E)-5-Decen-1-yl Acetate Synthesis]. BenchChem, [2026]. [Online PDF]. Available at: [\[https://www.benchchem.com/product/b107312/docs#technical-support-center-e-5-decen-1-yl-acetate-synthesis\]](https://www.benchchem.com/product/b107312/docs#technical-support-center-e-5-decen-1-yl-acetate-synthesis)

---

### Disclaimer & Data Validity:

The information provided in this document is for Research Use Only (RUO) and is strictly not intended for diagnostic or therapeutic procedures. While BenchChem strives to provide accurate protocols, we make no warranties, express or implied, regarding the fitness of this product for every specific experimental setup.

**Technical Support:** The protocols provided are for reference purposes. Unsure if this reagent suits your experiment?

**Need Industrial/Bulk Grade?** [Request Custom Synthesis Quote](#)

## BenchChem

Our mission is to be the trusted global source of essential and advanced chemicals, empowering scientists and researchers to drive progress in science and industry.

### Contact

Address: 3281 E Guasti Rd  
Ontario, CA 91761, United States  
Phone: (601) 213-4426  
Email: [info@benchchem.com](mailto:info@benchchem.com)

[Contact our Ph.D. Support Team for a compatibility check](#)