

# Application Note: Mass Spectrometric Characterization of 1,3,6,8-Tetrabromopyrene Derivatives

**Author:** BenchChem Technical Support Team. **Date:** December 2025

## Compound of Interest

Compound Name: 1,3,6,8-Tetrabromopyrene

Cat. No.: B107014

[Get Quote](#)

For Researchers, Scientists, and Drug Development Professionals

## Introduction

**1,3,6,8-Tetrabromopyrene** and its derivatives are a class of polycyclic aromatic hydrocarbons (PAHs) that have garnered significant interest in materials science and electronics due to their unique photophysical and electrochemical properties. Accurate characterization of these molecules is crucial for understanding their structure-property relationships and for the quality control of synthesized materials. Mass spectrometry is a powerful analytical technique for the determination of the molecular weight and structure of these compounds. This application note provides a detailed guide to the characterization of **1,3,6,8-tetrabromopyrene** derivatives using various mass spectrometry techniques, including recommended experimental protocols and an analysis of expected fragmentation patterns.

## Molecular Properties of 1,3,6,8-Tetrabromopyrene

A foundational understanding of the target molecule is essential before delving into its mass spectrometric analysis.

Property	Value	Reference
Molecular Formula	C <sub>16</sub> H <sub>6</sub> Br <sub>4</sub>	[1][2]
Average Molecular Weight	517.83 g/mol	[1]
Monoisotopic Mass	513.7203 Da	[1]

The presence of four bromine atoms results in a characteristic isotopic pattern in the mass spectrum, which is a key diagnostic feature for the identification of these compounds. Due to the natural abundance of the <sup>79</sup>Br and <sup>81</sup>Br isotopes, the molecular ion will appear as a cluster of peaks.

## Experimental Protocols

The choice of mass spectrometry technique and the specific experimental parameters will depend on the properties of the **1,3,6,8-tetrabromopyrene** derivative being analyzed, particularly its volatility and thermal stability.

### Protocol 1: Gas Chromatography-Mass Spectrometry (GC-MS)

GC-MS is suitable for volatile and thermally stable derivatives of **1,3,6,8-tetrabromopyrene**.

#### 1. Sample Preparation:

- Dissolve the sample in a high-purity organic solvent such as toluene, dichloromethane, or hexane to a final concentration of 1-10 µg/mL.
- If necessary, perform a cleanup step using solid-phase extraction (SPE) with a silica or alumina cartridge to remove impurities.
- Filter the final solution through a 0.22 µm PTFE syringe filter before injection.

#### 2. GC-MS Parameters:

Parameter	Recommended Setting
Gas Chromatograph	
Injection Mode	Splitless
Injector Temperature	300 °C
Carrier Gas	Helium at a constant flow of 1.0 mL/min
GC Column	30 m x 0.25 mm ID, 0.25 µm film thickness, 5% phenyl-methylpolysiloxane capillary column
Oven Program	Initial temperature of 100 °C, hold for 1 min, ramp to 320 °C at 15 °C/min, hold for 10 min
Mass Spectrometer	
Ionization Mode	Electron Ionization (EI) at 70 eV
Ion Source Temperature	230 °C
Quadrupole Temperature	150 °C
Mass Range	m/z 50-700
Scan Mode	Full Scan

## Protocol 2: Liquid Chromatography-Mass Spectrometry (LC-MS)

LC-MS is the preferred method for less volatile or thermally labile derivatives.

### 1. Sample Preparation:

- Dissolve the sample in a suitable organic solvent such as tetrahydrofuran (THF) or a mixture of acetonitrile and water to a concentration of 1-10 µg/mL.
- Ensure the sample solvent is compatible with the mobile phase to prevent precipitation.
- Filter the solution through a 0.22 µm syringe filter.

## 2. LC-MS Parameters:

Parameter	Recommended Setting
Liquid Chromatograph	
Column	C18 reverse-phase column (e.g., 150 mm x 2.1 mm, 3.5 $\mu$ m particle size)
Mobile Phase A	Water with 0.1% formic acid
Mobile Phase B	Acetonitrile with 0.1% formic acid
Gradient	Start with 50% B, increase to 100% B over 15 minutes, hold for 5 minutes, return to initial conditions
Flow Rate	0.3 mL/min
Column Temperature	40 °C
Mass Spectrometer	
Ionization Mode	Electrospray Ionization (ESI) in positive or negative mode, or Atmospheric Pressure Chemical Ionization (APCI)
Ion Source Temperature	350 °C (APCI)
Capillary Voltage	3.5 kV (ESI)
Mass Range	m/z 150-1000
Fragmentation	Collision-Induced Dissociation (CID) for MS/MS experiments

## Protocol 3: Matrix-Assisted Laser Desorption/Ionization-Time of Flight (MALDI-TOF) Mass Spectrometry

MALDI-TOF is particularly useful for the analysis of high molecular weight derivatives or for samples that are difficult to dissolve.<sup>[3][4]</sup>

## 1. Sample Preparation:

- **Matrix Selection:** A suitable matrix, such as  $\alpha$ -cyano-4-hydroxycinnamic acid (CHCA) or 2,5-dihydroxybenzoic acid (DHB), is crucial for successful MALDI analysis.
- **Sample-Matrix Co-crystallization:** Mix the sample solution (in a solvent like THF) with the matrix solution at a ratio of approximately 1:10 (sample:matrix).
- **Spotting:** Deposit a small volume (e.g., 1  $\mu$ L) of the mixture onto the MALDI target plate and allow it to air-dry to form crystals.

## 2. MALDI-TOF Parameters:

Parameter	Recommended Setting
Laser	Nitrogen laser (337 nm)
Mode	Positive ion reflectron mode
Acceleration Voltage	20 kV
Mass Range	m/z 500-5000 (or as needed for the derivative)

## Data Presentation and Interpretation

### Expected Mass Spectrum of 1,3,6,8-Tetrabromopyrene

The mass spectrum of **1,3,6,8-tetrabromopyrene** is expected to exhibit a prominent molecular ion cluster due to the presence of four bromine atoms. The relative abundances of the isotopic peaks can be predicted based on the natural abundances of  $^{79}\text{Br}$  and  $^{81}\text{Br}$ .

Table 1: Predicted Isotopic Distribution for the Molecular Ion of **1,3,6,8-Tetrabromopyrene** ( $\text{C}_{16}\text{H}_6\text{Br}_4$ )

Ion	m/z (Monoisotopic)	Description
[M] <sup>+</sup>	513.7203	Molecular ion containing four <sup>79</sup> Br atoms
[M+2] <sup>+</sup>	515.7183	Molecular ion containing three <sup>79</sup> Br and one <sup>81</sup> Br atom
[M+4] <sup>+</sup>	517.7162	Molecular ion containing two <sup>79</sup> Br and two <sup>81</sup> Br atoms
[M+6] <sup>+</sup>	519.7142	Molecular ion containing one <sup>79</sup> Br and three <sup>81</sup> Br atoms
[M+8] <sup>+</sup>	521.7121	Molecular ion containing four <sup>81</sup> Br atoms

## Fragmentation Pathways

Under electron ionization (EI) conditions, **1,3,6,8-tetrabromopyrene** is expected to undergo fragmentation primarily through the sequential loss of bromine atoms.

Table 2: Predicted Fragment Ions of **1,3,6,8-Tetrabromopyrene** in EI-MS

Fragment Ion	m/z (Monoisotopic)	Description
[M-Br] <sup>+</sup>	434.7998	Loss of one bromine radical
[M-2Br] <sup>+</sup>	355.8793	Loss of two bromine radicals
[M-3Br] <sup>+</sup>	276.9588	Loss of three bromine radicals
[M-4Br] <sup>+</sup>	198.0383	Loss of four bromine radicals (pyrene radical cation)
[M-HBr] <sup>+</sup>	433.8076	Loss of a hydrogen bromide molecule
[M-2HBr] <sup>+</sup>	353.8950	Loss of two hydrogen bromide molecules

## Visualizing Experimental Workflows and Fragmentation

To aid in the understanding of the analytical process and the interpretation of the resulting data, the following diagrams illustrate the experimental workflow and a plausible fragmentation pathway.

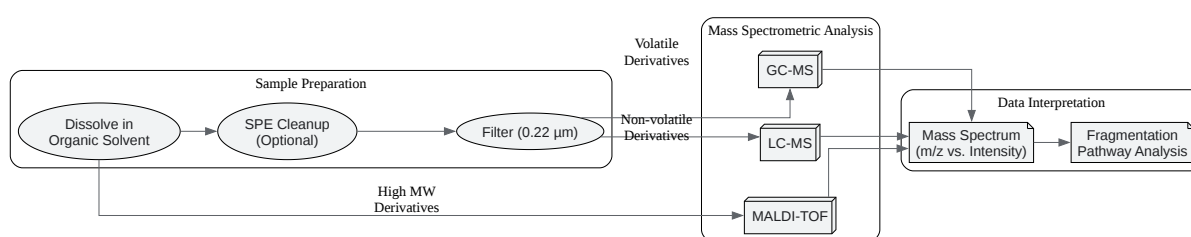

[Click to download full resolution via product page](#)

Experimental workflow for the mass spectrometric analysis of **1,3,6,8-tetrabromopyrene** derivatives.

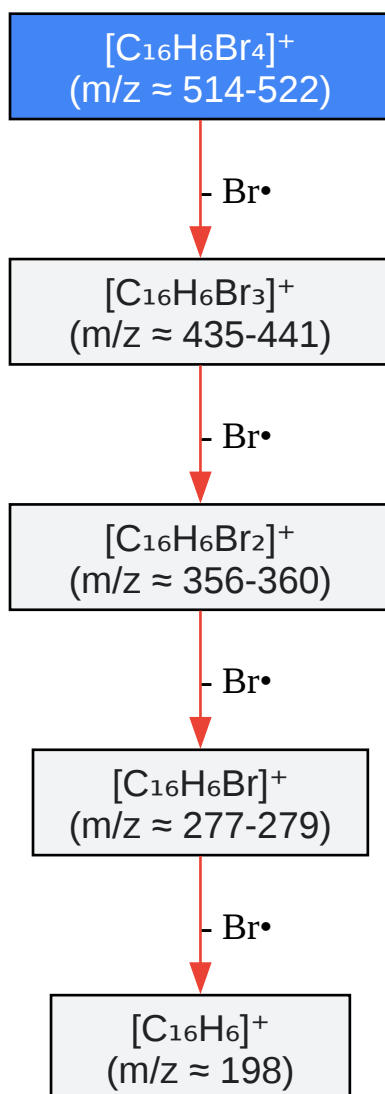

[Click to download full resolution via product page](#)

Proposed fragmentation pathway of **1,3,6,8-tetrabromopyrene** under electron ionization.

## Conclusion

The mass spectrometric characterization of **1,3,6,8-tetrabromopyrene** and its derivatives can be effectively achieved using GC-MS, LC-MS, or MALDI-TOF, depending on the analyte's properties. The presence of four bromine atoms provides a distinct isotopic signature that is invaluable for the identification of these compounds. The primary fragmentation pathway involves the sequential loss of bromine atoms, providing further structural confirmation. The protocols and data presented in this application note serve as a comprehensive guide for researchers in the successful characterization of this important class of molecules.



### Need Custom Synthesis?

BenchChem offers custom synthesis for rare earth carbides and specific isotopic labeling.

Email: [info@benchchem.com](mailto:info@benchchem.com) or [Request Quote Online](#).

## References

- 1. 1,3,6,8-Tetrabromopyrene | C<sub>16</sub>H<sub>6</sub>Br<sub>4</sub> | CID 67188 - PubChem [pubchem.ncbi.nlm.nih.gov]
- 2. 1,3,6,8-tetrabromopyrene | 128-63-2 [chemicalbook.com]
- 3. MALDI-TOF mass spectrometry of insoluble giant polycyclic aromatic hydrocarbons by a new method of sample preparation - PubMed [pubmed.ncbi.nlm.nih.gov]
- 4. pubs.acs.org [pubs.acs.org]
- To cite this document: BenchChem. [Application Note: Mass Spectrometric Characterization of 1,3,6,8-Tetrabromopyrene Derivatives]. BenchChem, [2025]. [Online PDF]. Available at: [https://www.benchchem.com/product/b107014#characterization-of-1-3-6-8-tetrabromopyrene-derivatives-using-mass-spectrometry]

---

### Disclaimer & Data Validity:

The information provided in this document is for Research Use Only (RUO) and is strictly not intended for diagnostic or therapeutic procedures. While BenchChem strives to provide accurate protocols, we make no warranties, express or implied, regarding the fitness of this product for every specific experimental setup.

**Technical Support:** The protocols provided are for reference purposes. Unsure if this reagent suits your experiment? [[Contact our Ph.D. Support Team for a compatibility check](#)]

**Need Industrial/Bulk Grade?** [Request Custom Synthesis Quote](#)

# BenchChem

Our mission is to be the trusted global source of essential and advanced chemicals, empowering scientists and researchers to drive progress in science and industry.

## Contact

Address: 3281 E Guasti Rd

Ontario, CA 91761, United States

Phone: (601) 213-4426

Email: [info@benchchem.com](mailto:info@benchchem.com)