

Introduction: The Strategic Importance of Dipeptide Building Blocks

Author: BenchChem Technical Support Team. **Date:** May 2026

Compound of Interest

Compound Name: z-Lys(Z)-gly-oh

CAS No.: 37941-54-1

Cat. No.: B106237

[Get Quote](#)

In the intricate field of peptide synthesis, the choice of building blocks is a critical determinant of success, directly impacting yield, purity, and the suppression of side reactions. While the stepwise addition of single amino acids is the conventional approach, the use of pre-formed dipeptide units offers a strategic advantage, particularly for challenging sequences. **Z-Lys(Z)-Gly-OH** is a quintessential example of such a strategic building block. This dipeptide, featuring the benzyloxycarbonyl (Z) protecting group on both the α -amino and ϵ -amino functions of lysine, is engineered to streamline the incorporation of the Lys-Gly motif into a growing peptide chain.

The primary rationale for using **Z-Lys(Z)-Gly-OH** is to overcome the synthetic hurdles associated with glycine. The steric hindrance of glycine is minimal, which can sometimes lead to undesirable side reactions or inefficient coupling in certain contexts. By incorporating lysine and glycine as a single, protected unit, researchers can enhance coupling efficiency and minimize the risk of deletion sequences or other impurities. This guide provides a comprehensive overview, detailed protocols, and the underlying scientific principles for leveraging **Z-Lys(Z)-Gly-OH** in both solution-phase and solid-phase peptide synthesis, tailored for researchers and professionals in drug development.

Physicochemical Properties of Key Reagents

A thorough understanding of the building blocks is fundamental. The properties of **Z-Lys(Z)-Gly-OH** and its constituent protected amino acids are summarized below.

Property	Z-Lys(Z)-OH	Z-Gly-OH	Z-Lys(Z)-Gly-OH
CAS Number	405-39-0[1]	1138-80-3[2]	15891-37-9 (illustrative)
Molecular Formula	C ₂₂ H ₂₆ N ₂ O ₆ [1]	C ₁₀ H ₁₁ NO ₄ [2]	C ₂₄ H ₂₉ N ₃ O ₇
Molecular Weight	414.45 g/mol [1]	209.21 g/mol	471.51 g/mol
Appearance	White to off-white solid[1]	Beige powder[2]	White to off-white solid
Primary Application	Peptide Synthesis[1]	Solution-phase peptide synthesis[2]	Solution & Solid-Phase Peptide Synthesis
Key Protecting Group	Benzyloxycarbonyl (Z or Cbz)[3]	Benzyloxycarbonyl (Z or Cbz)[3]	Benzyloxycarbonyl (Z or Cbz)

Core Concepts: The Role of the Z-Group in Peptide Synthesis

The benzyloxycarbonyl (Z or Cbz) group is one of the classical and most reliable N-protecting groups in peptide chemistry.[3] Its utility stems from its distinct stability profile.

- **Stability:** The Z-group is stable under the mildly basic conditions used for Fmoc-group removal (e.g., piperidine in DMF) and the acidic conditions used for Boc-group removal (e.g., TFA).[3][4] This orthogonality is crucial for complex synthetic strategies.
- **Deprotection:** The primary method for cleaving the Z-group is catalytic hydrogenolysis (e.g., H₂ over a palladium catalyst).[4] This process is exceptionally clean, yielding the free amine, toluene, and carbon dioxide as byproducts. Alternatively, strong acidic conditions like hydrogen bromide in acetic acid (HBr/AcOH) can be used.[3]

This unique deprotection mechanism allows for the selective unmasking of the lysine side chain or the N-terminus at a desired point in the synthesis, enabling strategies like fragment condensation or on-resin side-chain modification.

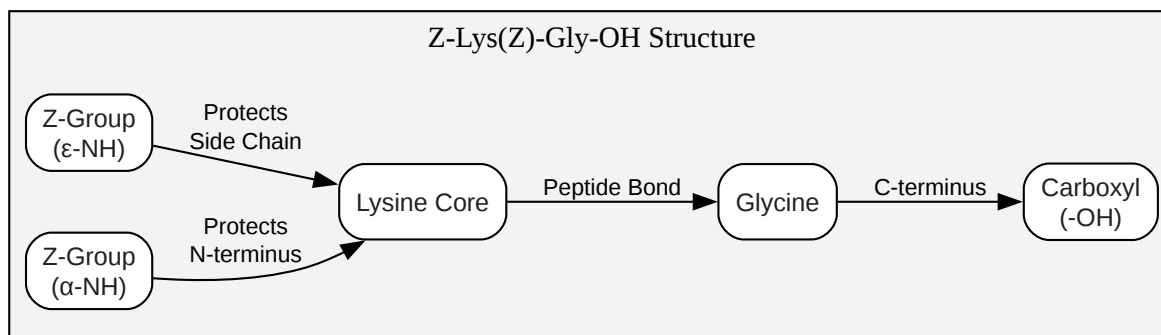

[Click to download full resolution via product page](#)

Caption: Logical structure of the **Z-Lys(Z)-Gly-OH** dipeptide.

Application in Solution-Phase Peptide Synthesis (SPPS)

Solution-phase synthesis, while often slower than solid-phase methods, is invaluable for large-scale production and the synthesis of peptide fragments for convergent strategies.^{[5][6]} **Z-Lys(Z)-Gly-OH** is exceptionally well-suited for this approach.

Protocol 1: Solution-Phase Coupling of Z-Lys(Z)-Gly-OH

This protocol describes the coupling of **Z-Lys(Z)-Gly-OH** to an amino acid C-terminal ester (e.g., H-Leu-OMe) using a carbodiimide activator.

Materials:

- **Z-Lys(Z)-Gly-OH** (1.0 eq)

- Amino acid ester hydrochloride (e.g., H-Leu-OMe·HCl) (1.05 eq)
- N,N'-Dicyclohexylcarbodiimide (DCC) or Diisopropylcarbodiimide (DIC) (1.1 eq)[7]
- 1-Hydroxybenzotriazole (HOBT) (1.1 eq)
- Base (e.g., N-Methylmorpholine, NMM, or Diisopropylethylamine, DIEA) (1.05 eq for neutralizing the HCl salt)
- Solvent: Anhydrous Dichloromethane (DCM) or Dimethylformamide (DMF)

Procedure:

- **Dissolution:** Dissolve **Z-Lys(Z)-Gly-OH** (1.0 eq) and HOBT (1.1 eq) in anhydrous DCM or DMF in a round-bottom flask under an inert atmosphere (e.g., Nitrogen or Argon).
- **Cooling:** Cool the solution to 0 °C in an ice bath. This is critical to minimize racemization during the activation step.[8]
- **Activation:** Add DCC or DIC (1.1 eq) to the cooled solution and stir for 15-20 minutes. If using DCC, a white precipitate of dicyclohexylurea (DCU) will begin to form.[7] The addition of HOBT is crucial as it forms an active ester intermediate that suppresses the risk of racemization.[7]
- **Amine Addition:** In a separate flask, dissolve the amino acid ester hydrochloride (1.05 eq) in DCM/DMF and neutralize it with the base (1.05 eq). Add this solution to the activated carboxyl solution at 0 °C.
- **Reaction:** Allow the reaction mixture to warm slowly to room temperature and stir overnight (12-18 hours).
- **Monitoring:** Monitor the reaction progress using Thin-Layer Chromatography (TLC) until the starting material (**Z-Lys(Z)-Gly-OH**) is consumed.
- **Work-up:**
 - Filter the reaction mixture to remove the precipitated urea byproduct (DCU).

- Transfer the filtrate to a separatory funnel and wash sequentially with 5% citric acid solution, saturated sodium bicarbonate (NaHCO_3) solution, and brine.
- Dry the organic layer over anhydrous sodium sulfate (Na_2SO_4), filter, and concentrate under reduced pressure.
- Purification: The resulting crude tripeptide can be purified by silica gel chromatography or recrystallization.

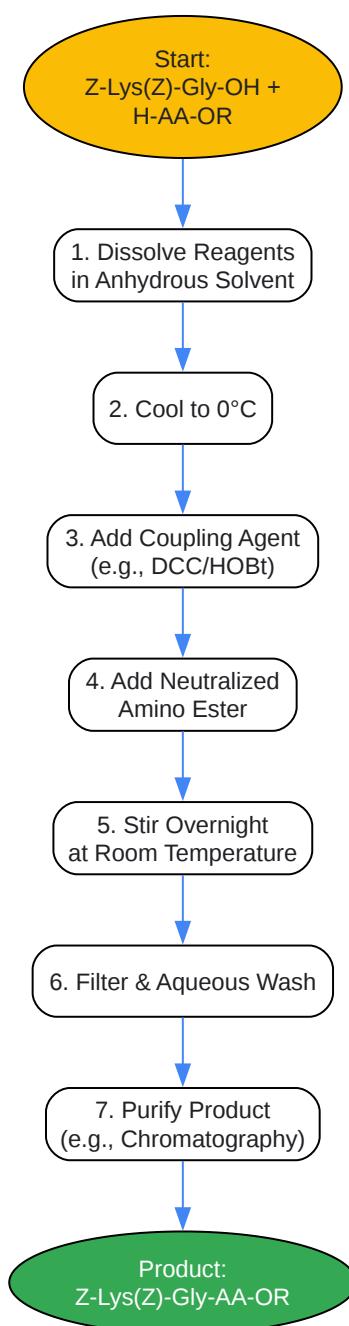

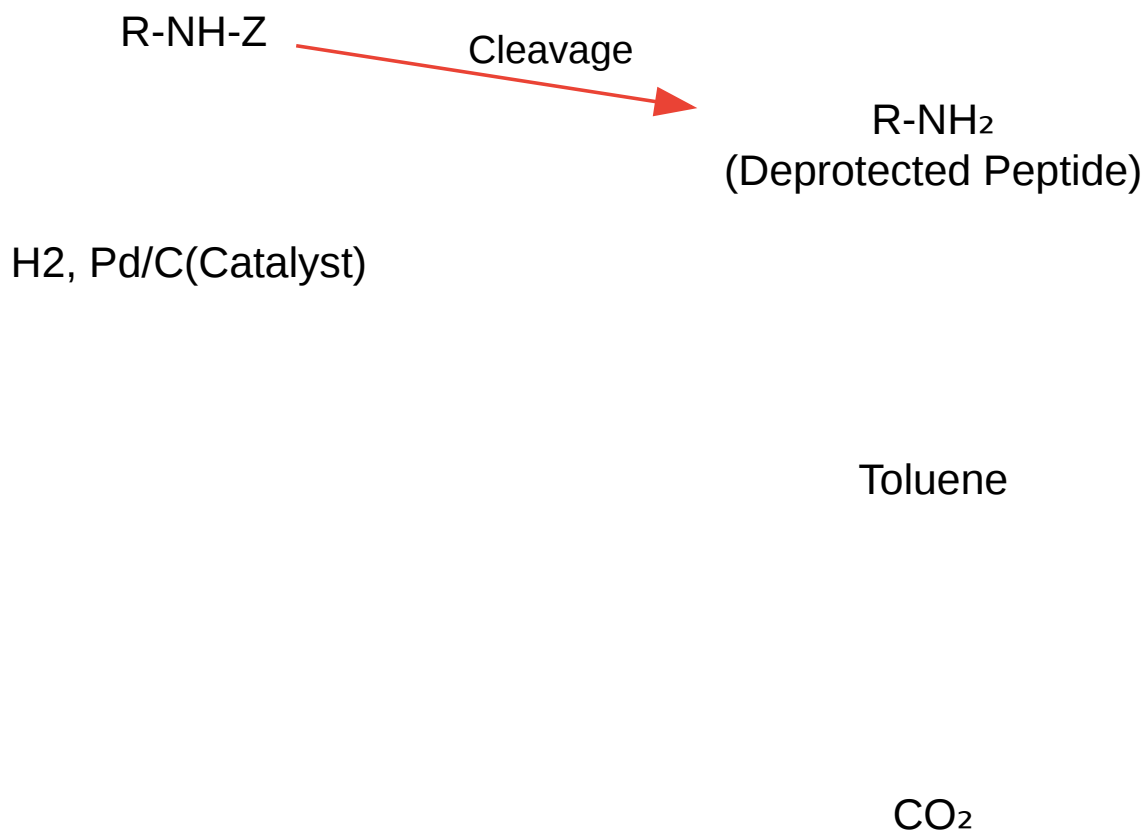

[Click to download full resolution via product page](#)

Caption: Catalytic hydrogenolysis for Z-group deprotection.

Purification and Final Analysis

After synthesis and complete deprotection, the crude peptide must be purified and characterized to ensure it meets the required specifications for research or drug development.

- Purification: The standard method for peptide purification is Reverse-Phase High-Performance Liquid Chromatography (RP-HPLC). [9] A C18 column is typically used with a gradient of water and an organic solvent (like acetonitrile), both containing a small amount of an ion-pairing agent such as TFA.
- Analysis: The purity of the final product is assessed by analytical RP-HPLC. The identity and molecular weight are confirmed using Mass Spectrometry (e.g., ESI-MS or MALDI-TOF). [10]

Conclusion

Z-Lys(Z)-Gly-OH is a powerful and strategic dipeptide building block that offers a reliable method for incorporating the Lys-Gly motif into synthetic peptides. Its robust Z-protection scheme provides orthogonality compatible with standard Boc and Fmoc strategies, while its use as a single unit can circumvent common problems associated with glycine coupling. By following well-defined protocols for coupling and deprotection via catalytic hydrogenolysis, researchers can achieve higher purity and better yields, accelerating the development of novel lysine-containing peptides for therapeutic and research applications.

References

- Google Patents. (n.d.). Production of peptides containing poly-gly sequences using fmoc chemistry.
- Fields, G. B. (n.d.). Practical Synthesis Guide to Solid Phase Peptide Chemistry. Retrieved from [\[Link\]](#)
- Organic & Biomolecular Chemistry. (2024). Chemical synthesis of site-selective advanced glycation end products in α -synuclein and its fragments. RSC Publishing. Retrieved from [\[Link\]](#)
- AAPPTec. (n.d.). Amino Acid Derivatives for Peptide Synthesis. Retrieved from [\[Link\]](#)
- PubMed Central. (2023). Selective Synthesis of Lysine Peptides and the Prebiotically Plausible Synthesis of Catalytically Active Diaminopropionic Acid Peptide Nitriles in Water. NIH. Retrieved from [\[Link\]](#)
- NIH. (n.d.). Facile solid phase peptide synthesis with a Re-lysine conjugate generated via a one-pot procedure. Retrieved from [\[Link\]](#)
- Digital CSIC. (n.d.). Supporting Information. Retrieved from [\[Link\]](#)
- UC Davis. (n.d.). Synthesis of hydrophilic and flexible linkers for peptide derivatization in solid phase. Retrieved from [\[Link\]](#)
- ResearchGate. (n.d.). Strategies for the synthesis of labeled peptides. Retrieved from [\[Link\]](#)

- RSC Publishing. (2017). Selective lysine modification of native peptides via aza-Michael addition. Retrieved from [[Link](#)]
- ScienceDirect. (n.d.). Recent development of peptide coupling reagents in organic synthesis. Retrieved from [[Link](#)]
- Hopax. (n.d.). Protecting Groups in Peptide Synthesis: A Detailed Guide. Retrieved from [[Link](#)]
- ResearchGate. (2019). Design of L-Lysine-Based Organogelators and Their Applications in Drug Release Processes. Retrieved from [[Link](#)]
- The Journal of Organic Chemistry. (n.d.). Solid-Phase Synthesis of Gly-Ψ[CH(CF₃)NH]-Peptides. Retrieved from [[Link](#)]
- Organic Chemistry Portal. (n.d.). Cbz-Protected Amino Groups. Retrieved from [[Link](#)]
- ACS Publications. (n.d.). Choosing the Right Coupling Reagent for Peptides: A Twenty-Five-Year Journey. Retrieved from [[Link](#)]
- ResearchGate. (2023). Development and Recent Advances in Lysine and N-Terminal Bioconjugation for Peptides and Proteins. Retrieved from [[Link](#)]
- Google Patents. (n.d.). Preparation of amino-protected lysine derivatives.
- PubMed. (n.d.). Development of a convenient peptide-based assay for lysyl hydroxylase. NIH. Retrieved from [[Link](#)]
- Aapptec Peptides. (n.d.). Coupling Reagents. Retrieved from [[Link](#)]
- Chemistry LibreTexts. (2025). 12.5: Peptide Synthesis- Solution-Phase. Retrieved from [[Link](#)]
- NIH. (n.d.). Development and Recent Advances in Lysine and N-Terminal Bioconjugation for Peptides and Proteins. Retrieved from [[Link](#)]
- Chemistry LibreTexts. (2024). 26.7: Peptide Synthesis. Retrieved from [[Link](#)]

- OSTI.GOV. (2007). Studies in Solid Phase Peptide Synthesis: A Personal Perspective. Retrieved from [[Link](#)]
- American Chemical Society. (2021). Solid-Phase Synthesis of Gly- Ψ [CH(CF₃)NH]-Peptides. Retrieved from [[Link](#)]
- Sartorius. (2025). Excellence in Peptide and Oligonucleotide Purification: Advanced Process Solutions. Retrieved from [[Link](#)]
- NIH. (2012). Discovery of lysine post-translational modifications through mass spectrometric detection. Retrieved from [[Link](#)]
- Wikipedia. (n.d.). Amino acid. Retrieved from [[Link](#)]

Need Custom Synthesis?

BenchChem offers custom synthesis for rare earth carbides and specific isotopic labeling.

Email: info@benchchem.com or [Request Quote Online](#).

Sources

- 1. [medchemexpress.com](https://www.medchemexpress.com) [[medchemexpress.com](https://www.medchemexpress.com)]
- 2. [Z-Gly-OH 99 1138-80-3](https://www.sigmaaldrich.com) [[sigmaaldrich.com](https://www.sigmaaldrich.com)]
- 3. [Protecting Groups in Peptide Synthesis: A Detailed Guide - Creative Peptides](https://www.creative-peptides.com) [[creative-peptides.com](https://www.creative-peptides.com)]
- 4. [peptide.com](https://www.peptide.com) [[peptide.com](https://www.peptide.com)]
- 5. [bachem.com](https://www.bachem.com) [[bachem.com](https://www.bachem.com)]
- 6. chem.libretexts.org [chem.libretexts.org]
- 7. [peptide.com](https://www.peptide.com) [[peptide.com](https://www.peptide.com)]
- 8. [bachem.com](https://www.bachem.com) [[bachem.com](https://www.bachem.com)]
- 9. [WO2010117725A2 - Production of peptides containing poly-gly sequences using fmoc chemistry - Google Patents](https://patents.google.com) [patents.google.com]
- 10. [Development of a convenient peptide-based assay for lysyl hydroxylase - PubMed](https://pubmed.ncbi.nlm.nih.gov) [pubmed.ncbi.nlm.nih.gov]

- To cite this document: BenchChem. [Introduction: The Strategic Importance of Dipeptide Building Blocks]. BenchChem, [2026]. [Online PDF]. Available at: [<https://www.benchchem.com/product/b106237/docs#introduction-the-strategic-importance-of-dipeptide-building-blocks>]

Disclaimer & Data Validity:

The information provided in this document is for Research Use Only (RUO) and is strictly not intended for diagnostic or therapeutic procedures. While BenchChem strives to provide accurate protocols, we make no warranties, express or implied, regarding the fitness of this product for every specific experimental setup.

Technical Support: The protocols provided are for reference purposes. Unsure if this reagent suits your experiment?

Need Industrial/Bulk Grade? [Request Custom Synthesis Quote](#)

BenchChem

Our mission is to be the trusted global source of essential and advanced chemicals, empowering scientists and researchers to drive progress in science and industry.

Contact

Address: 3281 E Guasti Rd
Ontario, CA 91761, United States
Phone: (601) 213-4426
Email: info@benchchem.com

[Contact our Ph.D. Support Team for a compatibility check](#)