

Technical Support Center: 2'-C-Methyladenosine Prodrug Activation Protocols

Author: BenchChem Technical Support Team. **Date:** April 2026

Compound of Interest

Compound Name: 2'-C-methyladenosine

CAS No.: 15397-12-3

Cat. No.: B103435

[Get Quote](#)

This technical support center provides troubleshooting guidance and frequently asked questions (FAQs) for researchers and drug development professionals working on the refinement of protocols for **2'-C-methyladenosine** prodrug activation.

Frequently Asked Questions (FAQs)

Q1: What is the primary rationale for using a prodrug approach for **2'-C-methyladenosine**?

A1: **2'-C-methyladenosine** is a potent inhibitor of viral RNA-dependent RNA polymerases, such as the hepatitis C virus (HCV) NS5B polymerase.^{[1][2]} However, its therapeutic potential is limited by rapid degradation by adenosine deaminase (ADA) in the bloodstream.^{[1][2]} Prodrug strategies are employed to mask the sites susceptible to ADA-mediated deamination, thereby improving the compound's metabolic stability and oral bioavailability.^{[1][2][3]}

Q2: What are the common enzymatic pathways responsible for the bioactivation of **2'-C-methyladenosine** prodrugs?

A2: The activation of **2'-C-methyladenosine** prodrugs is designed to occur intracellularly, releasing the active nucleoside monophosphate (NMP). Common activating enzymes include:

- Cytochrome P450 enzymes (e.g., CYP3A4): These are often involved in the oxidative cleavage of certain prodrug moieties, particularly in hepatocytes.[1][2]
- Carboxylesterases and other hydrolytic enzymes: These enzymes are crucial for cleaving ester-based prodrugs to release the parent nucleoside or nucleotide.[4]
- Phosphatases and Phosphodiesterases: While often involved in drug breakdown, specific prodrug designs can leverage these enzymes for activation. However, stability to these enzymes in plasma is also a design consideration.[3]
- Cellular Kinases: Following the release of the nucleoside monophosphate, cellular kinases are responsible for the subsequent phosphorylation steps to the active triphosphate form.[5][6]

Q3: Why is the first phosphorylation step often a rate-limiting factor in the activation of nucleoside analogs?

A3: The initial phosphorylation of a nucleoside to its 5'-monophosphate is frequently the slowest step in the activation cascade.[5][7] This can be due to the substrate specificity of the cellular kinases responsible for this conversion. To bypass this rate-limiting step, many prodrug strategies for **2'-C-methyladenosine** are designed as nucleotide prodrugs (e.g., phosphoramidates or "ProTides"), which directly release the monophosphate form inside the cell.[7][8]

Troubleshooting Guide

Issue	Possible Cause(s)	Suggested Solution(s)
<p>Low or undetectable levels of the active triphosphate (NTP) metabolite in cell-based assays.</p>	<p>1. Inefficient prodrug uptake into cells.2. Poor intracellular conversion of the prodrug to the monophosphate.3. The parent nucleoside is a poor substrate for cellular kinases.4. Rapid efflux of the prodrug or its metabolites from the cell.</p>	<p>1. Evaluate the physicochemical properties of the prodrug (e.g., lipophilicity) to ensure it can cross the cell membrane. Consider modifying the prodrug moiety to enhance permeability.[4][9]2. Select a cell line with high expression of the required activating enzymes (e.g., primary hepatocytes for CYP-mediated activation).[1][2] Alternatively, consider a different prodrug strategy that utilizes more ubiquitously expressed enzymes like carboxylesterases.[4]3. If using a nucleoside (not nucleotide) prodrug, confirm that the released 2'-C-methyladenosine is a substrate for the kinases in your cell line. If not, a nucleotide prodrug approach may be necessary.[5][7]4. Investigate the involvement of cellular efflux transporters and consider co-administration with known transporter inhibitors in your in vitro system.</p>
<p>High inter-experimental variability in prodrug activation levels.</p>	<p>1. Inconsistent cell health or passage number.2. Variability in the activity of activating enzymes between cell batches.3. Instability of the</p>	<p>1. Standardize cell culture conditions, including seeding density, growth phase, and passage number. Regularly test for mycoplasma contamination.2. For enzyme-</p>

	<p>prodrug in the cell culture medium.</p>	<p>dependent activation, ensure consistent expression levels of the relevant enzymes (e.g., through qPCR or western blotting).³ Assess the stability of the prodrug in your experimental medium over the time course of the assay. If unstable, consider shortening the incubation time or replenishing the compound.</p>
<p>Observed cytotoxicity is not correlated with the levels of the active NTP.</p>	<p>1. Off-target effects of the prodrug itself or a byproduct of its activation.² Mitochondrial toxicity.³ Inhibition of host DNA or RNA polymerases.</p>	<p>1. Synthesize and test inactive analogs of the prodrug to determine if the prodrug moiety itself is cytotoxic. Analyze for the formation of potentially toxic byproducts.² Evaluate mitochondrial function using assays that measure parameters like ATP levels or mitochondrial membrane potential. Some nucleoside analogs are known to inhibit mitochondrial DNA polymerase (POLG) or RNA polymerase (POLRMT).^[10]³ Perform in vitro assays to assess the inhibitory activity of the NTP against host polymerases.^[10]</p>
<p>Good in vitro activity but poor in vivo efficacy.</p>	<p>1. Poor oral bioavailability.² Rapid clearance in vivo.³ Inefficient activation in the target tissue.</p>	<p>1. Despite prodrug design, absorption may be limited. Investigate different formulation strategies or further modifications to the prodrug moiety to improve absorption.^[3]² Conduct pharmacokinetic studies to</p>

determine the half-life of the prodrug and its metabolites. If clearance is too rapid, consider modifications to the prodrug that reduce susceptibility to metabolic enzymes or renal excretion.³ Ensure that the animal model used for in vivo studies has a similar metabolic profile to humans for the enzymes required for prodrug activation. For liver-targeted prodrugs, confirm efficient delivery to and activation in hepatocytes.^{[1][2]}

Quantitative Data Summary

Table 1: In Vitro Antiviral Activity and Hepatocyte Metabolism of Selected **2'-C-Methyladenosine** Prodrugs

Compound	HCV Replicon EC50 (μM)	Primary Rat Hepatocyte NTP Formation ($\text{pmol}/10^6$ cells)
2'-C-Methyladenosine	0.4	1.2
Prodrug A (Cyclic 1-aryl-1,3-propanyl NMP)	1.2	150
Prodrug B (2',3'-carbonate derivative of Prodrug A)	0.8	250

Data is illustrative and compiled from concepts presented in cited literature. Actual values will vary based on specific molecular structures and experimental conditions.

Table 2: Pharmacokinetic Parameters of a **2'-C-Methyladenosine** Prodrug in Rats

Parameter	Intravenous Administration	Oral Administration
Dose	5 mg/kg	20 mg/kg
C _{max} (ng/mL)	1200	350
T _{max} (h)	0.25	1.5
AUC (ng·h/mL)	1800	2100
Oral Bioavailability (%)	-	39% ^{[1][2]}

This table represents conceptual data for a 2',3'-carbonate 1-(4-pyridyl)-1,3-propanyl NMP prodrug of **2'-C-methyladenosine** as described in the literature.^{[1][2]}

Experimental Protocols & Visualizations

General Workflow for Prodrug Activation and Antiviral Efficacy Testing

The following diagram outlines a typical experimental workflow for evaluating a novel **2'-C-methyladenosine** prodrug.

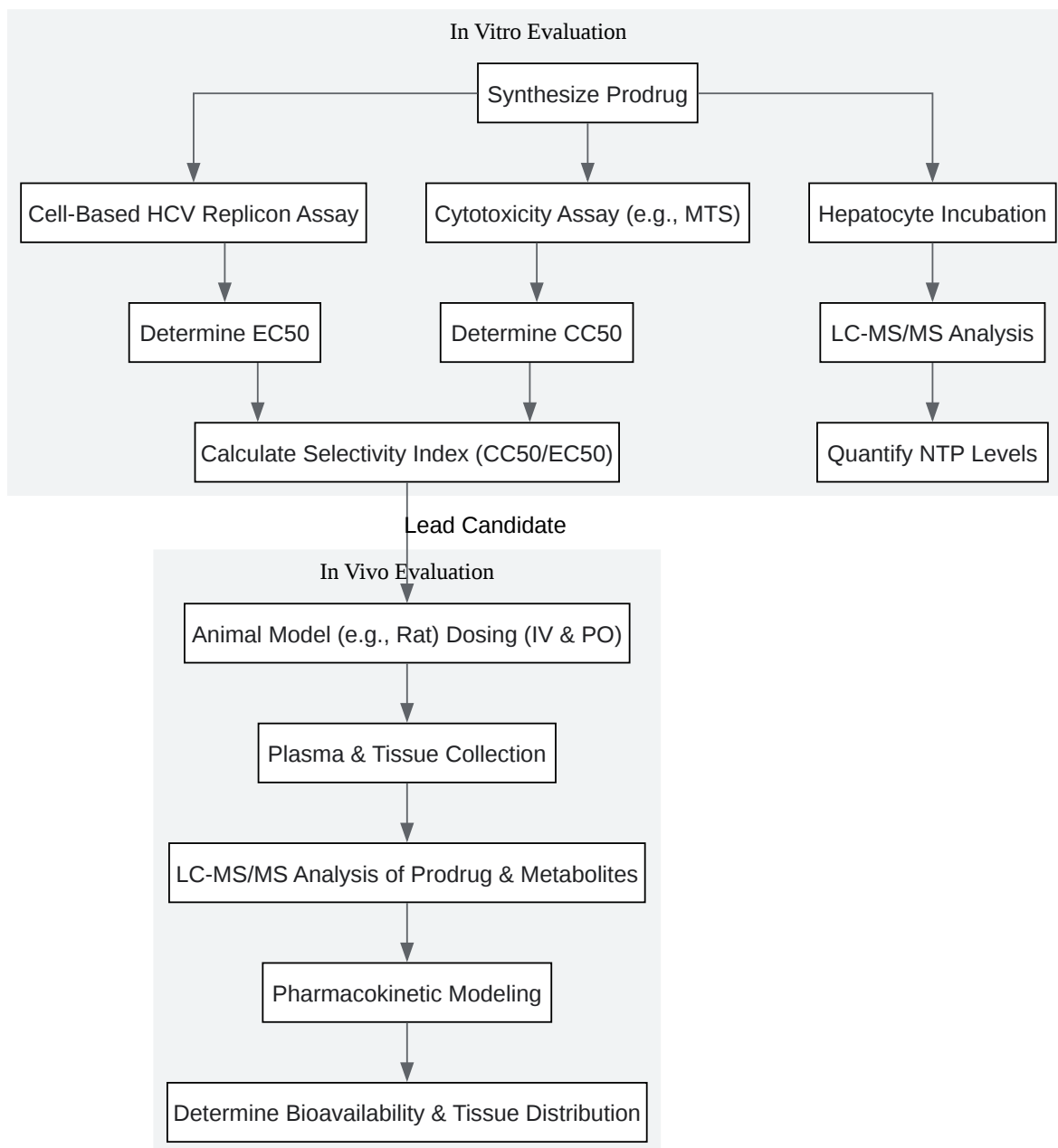

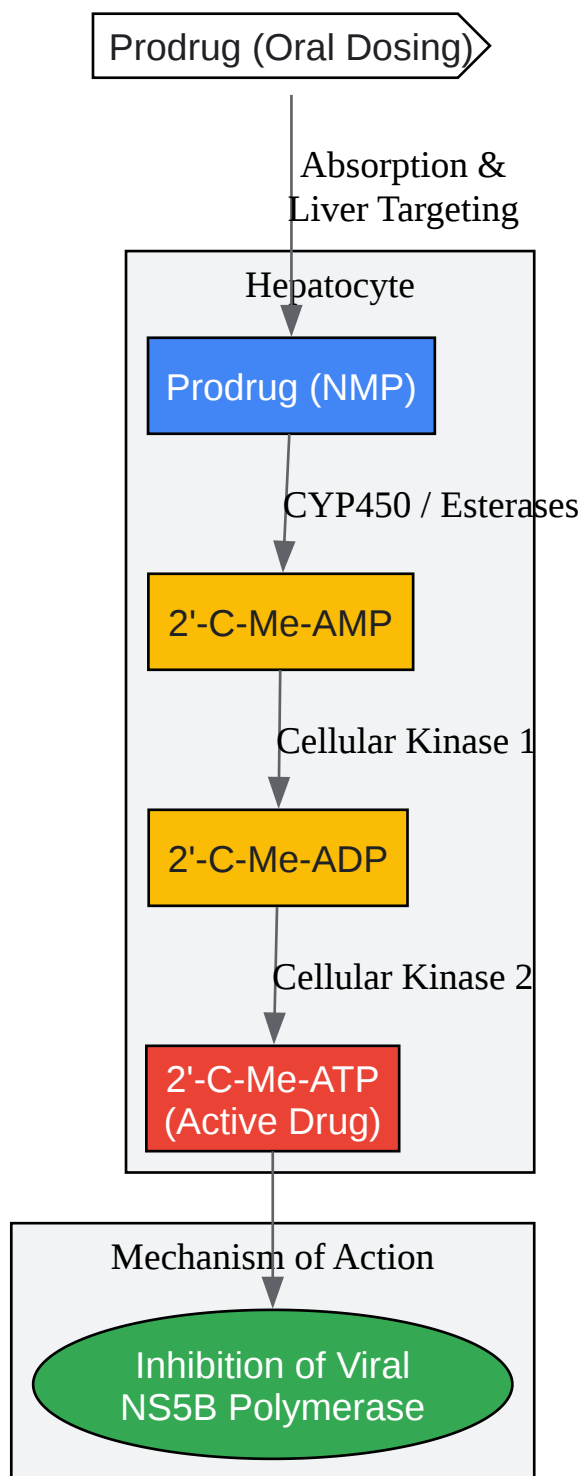

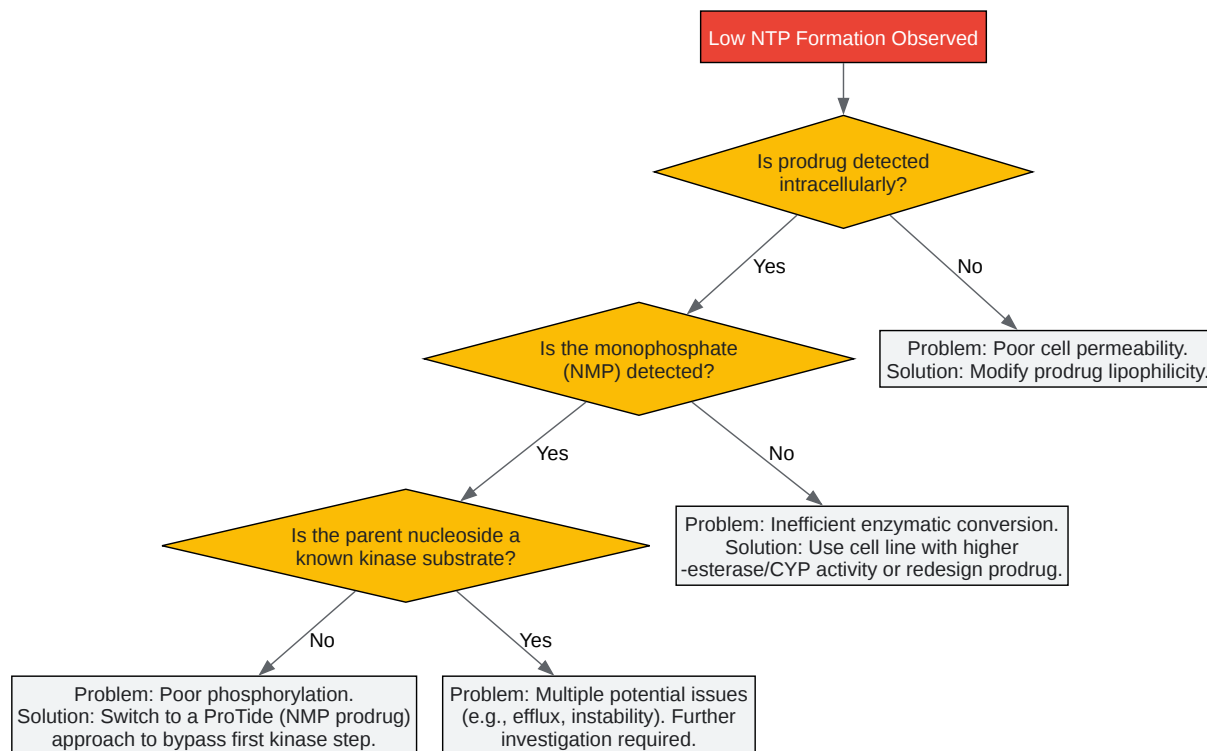

[Click to download full resolution via product page](#)

Need Custom Synthesis?

BenchChem offers custom synthesis for rare earth carbides and specific isotopic labeling.

Email: info@benchchem.com or [Request Quote Online](#).

References

- 1. Collection - Liver-Targeted Prodrugs of 2'-C-Methyladenosine for Therapy of Hepatitis C Virus Infection - Journal of Medicinal Chemistry - Figshare [[acs.figshare.com](https://www.acs.figshare.com)]
- 2. Liver-targeted prodrugs of 2'-C-methyladenosine for therapy of hepatitis C virus infection - PubMed [pubmed.ncbi.nlm.nih.gov]
- 3. Prodrug strategies for improved efficacy of nucleoside antiviral inhibitors - PMC [[pmc.ncbi.nlm.nih.gov](https://pubmed.ncbi.nlm.nih.gov)]
- 4. Prodrugs for Improved Drug Delivery: Lessons Learned from Recently Developed and Marketed Products - PMC [[pmc.ncbi.nlm.nih.gov](https://pubmed.ncbi.nlm.nih.gov)]
- 5. Prodrug approaches to improving the oral absorption of antiviral nucleotide analogues - PMC [[pmc.ncbi.nlm.nih.gov](https://pubmed.ncbi.nlm.nih.gov)]
- 6. [mdpi.com](https://www.mdpi.com) [[mdpi.com](https://www.mdpi.com)]
- 7. [researchgate.net](https://www.researchgate.net) [[researchgate.net](https://www.researchgate.net)]
- 8. Advanced Prodrug Strategies in Nucleoside and Non-Nucleoside Antiviral Agents: A Review of the Recent Five Years - PMC [[pmc.ncbi.nlm.nih.gov](https://pubmed.ncbi.nlm.nih.gov)]
- 9. Prodrug Approaches for Improved DMPK Characteristics and Their Preclinical Study Considerations - WuXi AppTec DMPK [dmpk.wuxiapptec.com]
- 10. Addressing the selectivity and toxicity of antiviral nucleosides - PMC [[pmc.ncbi.nlm.nih.gov](https://pubmed.ncbi.nlm.nih.gov)]
- To cite this document: BenchChem. [Technical Support Center: 2'-C-Methyladenosine Prodrug Activation Protocols]. BenchChem, [2026]. [Online PDF]. Available at: [<https://www.benchchem.com/product/b103435/docs#technical-support-center-2-c-methyladenosine-prodrug-activation-protocols>]

Disclaimer & Data Validity:

The information provided in this document is for Research Use Only (RUO) and is strictly not intended for diagnostic or therapeutic procedures. While BenchChem strives to provide accurate protocols, we make no warranties, express or implied, regarding the fitness of this product for every specific experimental setup.

Technical Support: The protocols provided are for reference purposes. Unsure if this reagent suits your experiment?

Need Industrial/Bulk Grade? [Request Custom Synthesis Quote](#)

BenchChem

Our mission is to be the trusted global source of essential and advanced chemicals, empowering scientists and researchers to drive progress in science and industry.

Contact

Address: 3281 E Guasti Rd
Ontario, CA 91761, United States
Phone: (601) 213-4426
Email: info@benchchem.com

[Contact our Ph.D. Support Team for a compatibility check](#)