

Potential research areas for alkyl nitriles

Author: BenchChem Technical Support Team. **Date:** December 2025

Compound of Interest

Compound Name: 5-Methylhexanenitrile

Cat. No.: B103281

[Get Quote](#)

An In-depth Technical Guide to Potential Research Areas for Alkyl Nitriles

Abstract

The nitrile group, a seemingly simple functional moiety composed of a carbon triple-bonded to a nitrogen atom, is a cornerstone of modern chemical and biological sciences. Its unique electronic properties, linear geometry, and versatile reactivity make it a critical building block in a vast array of applications. This technical guide provides an in-depth exploration of the burgeoning research areas centered around alkyl nitriles, tailored for researchers, scientists, and professionals in drug development. We will traverse the landscape of medicinal chemistry, where the nitrile group is a celebrated pharmacophore, through advanced organic synthesis, where it serves as a versatile intermediate. Furthermore, we will examine its emerging roles in materials science, particularly in the development of high-performance battery electrolytes, and its profound implications in astrochemistry and the origins of life. This guide integrates quantitative data, detailed experimental protocols, and logical visualizations to illuminate the core concepts and future directions in the dynamic field of nitrile chemistry.

The Nitrile Moiety: Physicochemical Properties and Reactivity

The cyano group ($-C\equiv N$) endows molecules with a unique set of characteristics. Its strong electron-withdrawing nature and significant dipole moment influence molecular polarity, solubility, and metabolic stability.[1][2] The linear geometry of the sp -hybridized carbon is another key feature, allowing it to be accommodated within sterically congested environments like protein active sites.[3] While generally robust and metabolically stable, the nitrile group is

not inert.[2][4] It can be hydrolyzed to carboxylic acids or amides, reduced to primary amines, or undergo addition reactions with organometallic reagents to form ketones, making it a highly versatile synthetic handle.[5][6] This duality of stability and reactivity is central to its utility across various scientific disciplines.

Research Area: Medicinal Chemistry and Drug Development

The incorporation of a nitrile group has become a prominent strategy in rational drug design.[7] Over 30 nitrile-containing pharmaceuticals are currently marketed for a wide range of diseases, with many more in clinical development.[1][3] Since 2010, the U.S. FDA has approved at least one new nitrile-containing drug each year.[1]

Key Roles of the Nitrile Group in Drug Design

The nitrile group's value in medicinal chemistry stems from its ability to modulate multiple molecular properties simultaneously:

- **Bioisosterism:** The nitrile is frequently used as a bioisostere for carbonyl, hydroxyl, and carboxyl groups, as well as halogen atoms.[3][8] It can act as a hydrogen bond acceptor, engaging with amino acid residues like serine and arginine in protein binding pockets.[3][4]
- **Enhancing Binding Affinity:** The strong dipole moment facilitates polar interactions, and the electron-poor nature of the nitrile can optimize π - π stacking interactions with aromatic residues in a target protein.[1]
- **Improving Pharmacokinetics (PK):** Introducing a nitrile group can block metabolically labile sites, increasing metabolic stability and prolonging a drug's half-life.[2][9] It can also improve solubility and membrane permeability, leading to enhanced bioavailability.[1][2]
- **Covalent Inhibition:** The electrophilic carbon of the nitrile can be attacked by nucleophilic residues (e.g., cysteine, serine) in an enzyme's active site, leading to the formation of a reversible or irreversible covalent bond.[2] This mechanism is exploited in several classes of inhibitors.

Table of Representative Nitrile-Containing Pharmaceuticals

The following table summarizes key data for several major drugs where the nitrile group plays a critical role.

Drug Name	Therapeutic Area	Target/Mechanism of Action	Role of Nitrile Group
Vildagliptin	Type 2 Diabetes	Dipeptidyl peptidase-4 (DPP-IV) inhibitor	Forms a reversible covalent adduct with the active site serine. [3]
Anastrozole	Breast Cancer	Aromatase inhibitor	Interacts with the heme iron and polar amino acids in the active site.[3]
Letrozole	Breast Cancer	Aromatase inhibitor	Binds to the heme iron of cytochrome P450, inhibiting estrogen synthesis.
Ruxolitinib	Myelofibrosis	Janus kinase (JAK) inhibitor	Key binding interactions within the ATP-binding pocket of JAK1/2.[1]
Tofacitinib	Rheumatoid Arthritis	Janus kinase (JAK) inhibitor	Occupies the ribose pocket and interacts with the protein backbone.[1]
Bicalutamide	Prostate Cancer	Androgen receptor antagonist	Participates in hydrogen bonding, mimicking the 3-keto group of dihydrotestosterone. [4]
Verelan (Verapamil)	Hypertension	Calcium channel blocker	Contributes to the overall physicochemical properties required for activity.[3]

Remdesivir	Antiviral (COVID-19)	RNA-dependent RNA polymerase inhibitor	The 1'-cyano group provides steric hindrance that blocks RNA polymerase translocation.[5]
------------	----------------------	--	---

Signaling Pathway: Covalent Inhibition by α -Amino Nitriles

α -Amino nitrile drugs, such as the DPP-IV inhibitors used for treating diabetes, function through a mechanism of reversible covalent inhibition. The diagram below illustrates this process, where the nitrile group is attacked by an active site serine residue.

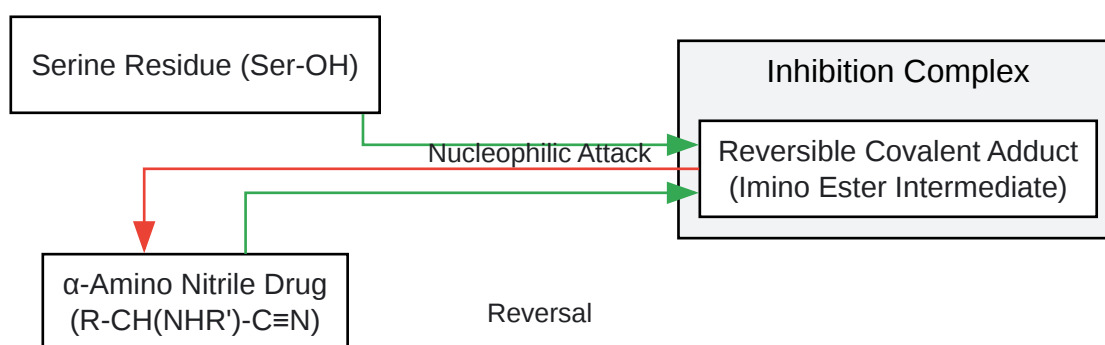

[Click to download full resolution via product page](#)

Mechanism of reversible covalent inhibition by α -amino nitrile drugs.

Experimental Protocol: DPP-IV Inhibition Assay

This protocol outlines a general method for determining the inhibitory activity of a nitrile-containing compound against Dipeptidyl Peptidase-IV (DPP-IV).

Objective: To determine the IC₅₀ value of a test compound.

Materials:

- Human recombinant DPP-IV enzyme
- DPP-IV substrate: Gly-Pro-p-nitroanilide (G-p-NA)

- Assay Buffer: Tris-HCl buffer (pH 7.5)
- Test compound (e.g., an alkyl nitrile derivative) dissolved in DMSO
- 96-well microplate
- Microplate reader capable of measuring absorbance at 405 nm

Procedure:

- **Compound Preparation:** Prepare a serial dilution of the test compound in DMSO. A typical starting concentration might be 1 mM, diluted down to the nM range.
- **Assay Setup:** In each well of the 96-well plate, add:
 - 80 μ L of Assay Buffer
 - 10 μ L of the test compound dilution (or DMSO for control wells)
 - 10 μ L of the DPP-IV enzyme solution.
- **Pre-incubation:** Incubate the plate at 37°C for 15 minutes to allow the inhibitor to bind to the enzyme.
- **Reaction Initiation:** Add 10 μ L of the G-p-NA substrate solution to each well to start the enzymatic reaction.
- **Kinetic Measurement:** Immediately place the plate in the microplate reader and measure the absorbance at 405 nm every minute for 30 minutes at 37°C. The product, p-nitroanilide, is yellow and absorbs at this wavelength.
- **Data Analysis:**
 - Calculate the rate of reaction (slope of the absorbance vs. time plot) for each well.
 - Determine the percent inhibition for each concentration of the test compound relative to the DMSO control.

- Plot the percent inhibition against the logarithm of the inhibitor concentration and fit the data to a dose-response curve to calculate the IC50 value.

Research Area: Advanced Organic Synthesis

Alkyl nitriles are fundamental building blocks in organic synthesis due to the cyano group's ability to be transformed into a wide range of other functional groups.^[5] The development of novel and efficient methods for introducing the cyano group—a process known as cyanation—is a highly active area of research.^{[10][11]}

Modern Cyanation Methodologies

Traditional methods like the Sandmeyer and Rosenmund-von Braun reactions often require harsh conditions and stoichiometric, toxic reagents.^{[12][13]} Modern research focuses on transition-metal-catalyzed approaches that offer milder conditions, broader substrate scope, and higher functional group tolerance.^[11]

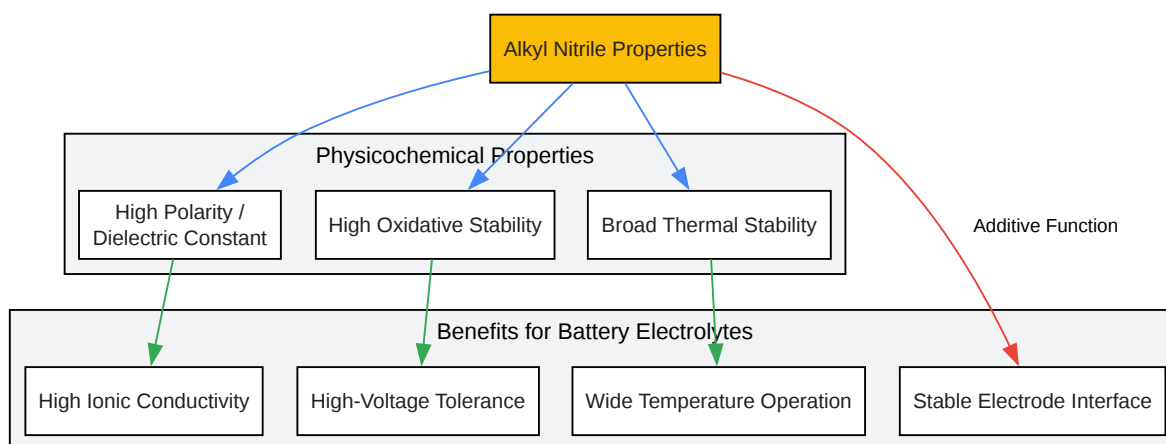
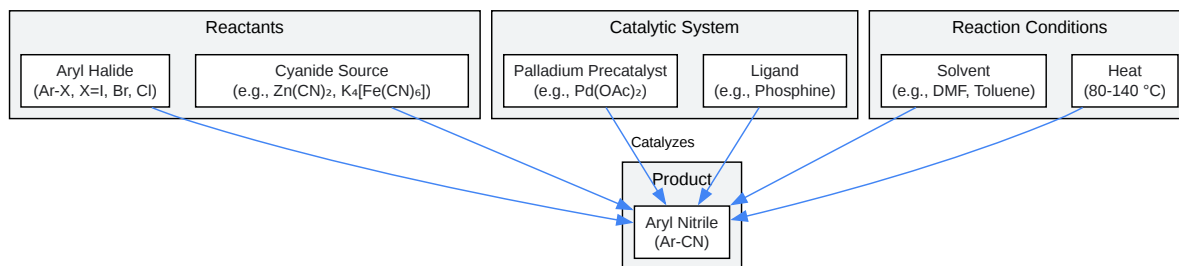

[Click to download full resolution via product page](#)

Need Custom Synthesis?

BenchChem offers custom synthesis for rare earth carbides and specific isotopic labeling.

Email: info@benchchem.com or [Request Quote Online](#).

References

- 1. Nitrile-containing pharmaceuticals: target, mechanism of action, and their SAR studies - PMC [pmc.ncbi.nlm.nih.gov]
- 2. Nitriles: an attractive approach to the development of covalent inhibitors - PMC [pmc.ncbi.nlm.nih.gov]
- 3. Nitrile-Containing Pharmaceuticals: Efficacious Roles of the Nitrile Pharmacophore - PMC [pmc.ncbi.nlm.nih.gov]
- 4. pubs.acs.org [pubs.acs.org]
- 5. scielo.br [scielo.br]
- 6. chem.libretexts.org [chem.libretexts.org]
- 7. Nitrile-containing pharmaceuticals: target, mechanism of action, and their SAR studies - RSC Medicinal Chemistry (RSC Publishing) [pubs.rsc.org]
- 8. A survey of the role of nitrile groups in protein-ligand interactions - PubMed [pubmed.ncbi.nlm.nih.gov]
- 9. researchgate.net [researchgate.net]
- 10. Cyanation - Wikipedia [en.wikipedia.org]
- 11. Recent advances and prospects in the palladium-catalyzed cyanation of aryl halides - RSC Advances (RSC Publishing) DOI:10.1039/D0RA05960A [pubs.rsc.org]
- 12. researchgate.net [researchgate.net]
- 13. taylorandfrancis.com [taylorandfrancis.com]
- To cite this document: BenchChem. [Potential research areas for alkyl nitriles]. BenchChem, [2025]. [Online PDF]. Available at: [https://www.benchchem.com/product/b103281#potential-research-areas-for-alkyl-nitriles]

Disclaimer & Data Validity:

The information provided in this document is for Research Use Only (RUO) and is strictly not intended for diagnostic or therapeutic procedures. While BenchChem strives to provide accurate protocols, we make no warranties, express or implied, regarding the fitness of this product for every specific experimental setup.

Technical Support: The protocols provided are for reference purposes. Unsure if this reagent suits your experiment? [[Contact our Ph.D. Support Team for a compatibility check](#)]

Need Industrial/Bulk Grade? [Request Custom Synthesis Quote](#)

BenchChem

Our mission is to be the trusted global source of essential and advanced chemicals, empowering scientists and researchers to drive progress in science and industry.

Contact

Address: 3281 E Guasti Rd
Ontario, CA 91761, United States
Phone: (601) 213-4426
Email: info@benchchem.com