

Application Notes and Protocols for Testing 2'-C-methyladenosine Efficacy

Author: BenchChem Technical Support Team. **Date:** April 2026

Compound of Interest

Compound Name: 2'-C-methyladenosine

CAS No.: 15397-12-3

Cat. No.: B103435

[Get Quote](#)

For Researchers, Scientists, and Drug Development Professionals

Introduction

2'-C-methyladenosine is a nucleoside analog that has demonstrated potent inhibitory activity against the Hepatitis C Virus (HCV).^{[1][2]} Its primary mechanism of action involves the intracellular conversion to its triphosphate form, which then acts as a chain terminator for the HCV RNA-dependent RNA polymerase (NS5B), an enzyme essential for viral replication.^{[1][2]} This document provides detailed application notes and experimental protocols for assessing the in vitro and in vivo efficacy of **2'-C-methyladenosine** and its derivatives against HCV.

These guidelines are designed to assist researchers in the preclinical evaluation of this compound, covering key assays for determining antiviral activity, cytotoxicity, and preliminary in vivo efficacy.

Data Presentation

All quantitative data from the described experiments should be summarized in clear and well-structured tables to facilitate comparison and interpretation of results.

Table 1: In Vitro Efficacy and Cytotoxicity of **2'-C-methyladenosine**

Compound	Assay Type	Cell Line	EC ₅₀ (μM)	CC ₅₀ (μM)	Selectivity Index (SI = CC ₅₀ /EC ₅₀)
2'-C-methyladenosine	HCV Replicon Assay	Huh-7			
(Genotype 1b)					
2'-C-methyladenosine	HCV Replicon Assay	Huh-7			
(Genotype 2a)					
Positive Control	HCV Replicon Assay	Huh-7			
(e.g., Sofosbuvir) (Genotype 1b)					
Negative Control	HCV Replicon Assay	Huh-7	> Max Conc.	> Max Conc.	N/A
(e.g., Vehicle) (Genotype 1b)					

 Table 2: In Vivo Efficacy of **2'-C-methyladenosine** in HCV Xenograft Mouse Model

Treatment Group	Dose (mg/kg)	Route of Administration	Mean HCV RNA Reduction (log ₁₀ IU/mL)	Tumor Volume Change (%)	Body Weight Change (%)
Vehicle Control	N/A	e.g., Oral			
2'-C-methyladenosine	e.g., Oral				
Positive Control	e.g., Oral				
(e.g., BILN 2061)					

Experimental Protocols

In Vitro Efficacy and Cytotoxicity Assays

1. HCV Replicon Assay

This assay is a cornerstone for evaluating the anti-HCV activity of compounds in a cell-based system. It utilizes human hepatoma cells (Huh-7) that harbor a subgenomic HCV replicon, which autonomously replicates its RNA.^{[2][3][4][5]}

Protocol:

- **Cell Plating:** Seed Huh-7 cells harboring an HCV replicon (e.g., genotype 1b or 2a with a luciferase reporter) in 96-well plates at a density of 5×10^3 to 1×10^4 cells per well in Dulbecco's Modified Eagle Medium (DMEM) supplemented with 10% Fetal Bovine Serum (FBS), 1% non-essential amino acids, and G418 for selection.^[3] Incubate at 37°C in a 5% CO₂ incubator overnight.
- **Compound Preparation:** Prepare a serial dilution of **2'-C-methyladenosine** in DMSO. The final DMSO concentration in the cell culture medium should not exceed 0.5% to avoid

toxicity.[3]

- Treatment: Add the diluted compounds to the cells in triplicate. Include a positive control (e.g., a known HCV inhibitor like sofosbuvir) and a negative control (DMSO vehicle).[3]
- Incubation: Incubate the plates for 72 hours at 37°C in a 5% CO₂ incubator.[3]
- Quantification of HCV Replication: If using a luciferase reporter replicon, lyse the cells and measure luciferase activity using a commercial kit according to the manufacturer's instructions. Luminescence is proportional to the level of HCV RNA replication.
- Data Analysis: Calculate the 50% effective concentration (EC₅₀), which is the concentration of the compound that inhibits HCV replication by 50%, using a non-linear regression analysis of the dose-response curve.[3]

2. Cytotoxicity Assay (CC₅₀ Determination)

It is crucial to assess the toxicity of the compound to the host cells to determine its therapeutic window.[6][7]

Protocol:

- Cell Plating: Seed parental Huh-7 cells (without the replicon) in 96-well plates at the same density as the replicon assay.
- Compound Treatment: Treat the cells with the same serial dilutions of **2'-C-methyladenosine** as in the replicon assay.
- Incubation: Incubate for 72 hours at 37°C in a 5% CO₂ incubator.
- Cell Viability Assessment: Use a commercial cell viability reagent (e.g., CellTiter 96 AQueous One Solution Reagent) that measures the conversion of a tetrazolium compound into a colored formazan product by viable cells.[1] Measure the absorbance at 490 nm.
- Data Analysis: Calculate the 50% cytotoxic concentration (CC₅₀), the concentration that reduces cell viability by 50%, using a non-linear regression analysis.[1][6] The Selectivity Index (SI) is then calculated as CC₅₀/EC₅₀. A higher SI value indicates a more favorable therapeutic window.[6]

3. HCV NS5B Polymerase Inhibition Assay

This biochemical assay directly measures the inhibitory effect of the compound on the enzymatic activity of the HCV RNA-dependent RNA polymerase (NS5B).

Protocol:

- **Reaction Mixture:** Prepare a reaction mixture containing purified recombinant HCV NS5B protein, a biotinylated oligo(U) primer, a poly(A) template, and a reaction buffer (e.g., 20 mM Tris-HCl pH 7.5, 5 mM MgCl₂, 1 mM DTT).[8]
- **Compound Addition:** Add varying concentrations of **2'-C-methyladenosine** triphosphate (the active form) to the reaction mixture.
- **Initiation of Reaction:** Start the polymerase reaction by adding a mixture of unlabeled NTPs and a radiolabeled NTP (e.g., [³H]UTP).[8]
- **Incubation:** Incubate the reaction at room temperature for a defined period (e.g., 90 minutes).[8]
- **Termination and Detection:** Stop the reaction and capture the biotinylated primer-template complex on streptavidin-coated beads.[8] Measure the incorporation of the radiolabeled nucleotide using a scintillation counter.
- **Data Analysis:** Determine the IC₅₀ value, which is the concentration of the compound that inhibits NS5B polymerase activity by 50%.

In Vivo Efficacy Model

1. HCV Replicon Xenograft Mouse Model

This model utilizes immunodeficient mice implanted with human hepatoma cells harboring an HCV replicon to assess the in vivo efficacy of antiviral compounds.[9][10]

Protocol:

- **Cell Line Adaptation:** Use a Huh-7 cell line containing a mouse-adapted HCV replicon with a reporter gene like luciferase for non-invasive imaging.[9]

- Animal Model: Use immunodeficient mice (e.g., SCID mice).[9]
- Tumor Implantation: Subcutaneously implant the replicon-containing Huh-7 cells into the flanks of the mice.[9]
- Monitoring Tumor Growth and Replicon Activity: Monitor tumor growth by caliper measurements. Monitor HCV RNA replication by non-invasive whole-body imaging for luciferase activity.[9]
- Drug Treatment: Once tumors are established and a stable bioluminescence signal is detected, randomize the mice into treatment groups (vehicle control, **2'-C-methyladenosine** at different doses, and a positive control). Administer the compounds via the desired route (e.g., oral gavage).
- Efficacy Assessment: Monitor the bioluminescence signal throughout the treatment period to assess the reduction in HCV RNA replication.[9] At the end of the study, collect tumors and blood for HCV RNA quantification by qRT-PCR.[11]
- Toxicity Monitoring: Monitor the general health of the animals, including body weight, throughout the study.

Visualizations

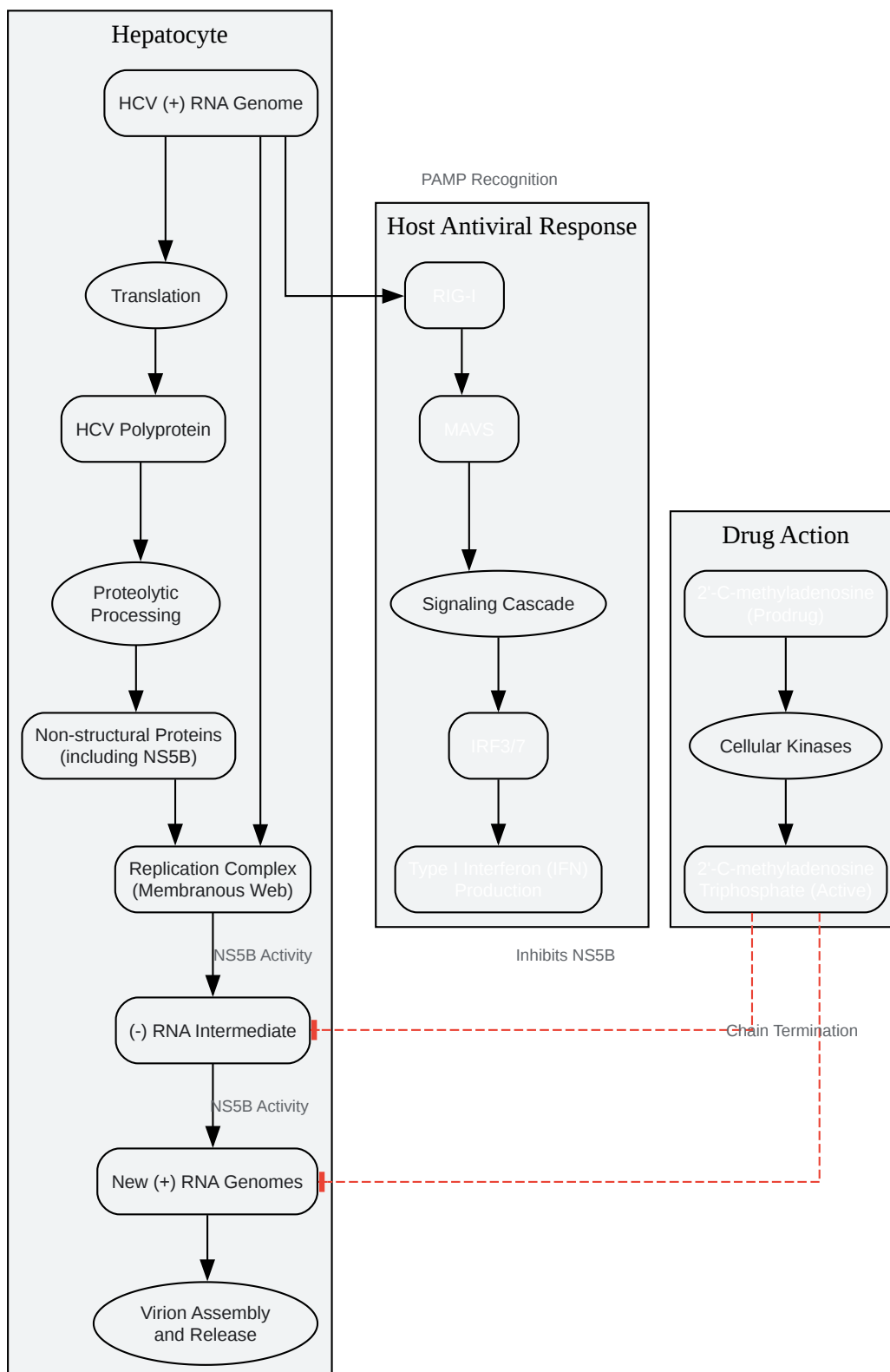

[Click to download full resolution via product page](#)

Caption: Mechanism of action of **2'-C-methyladenosine** and host antiviral response to HCV.

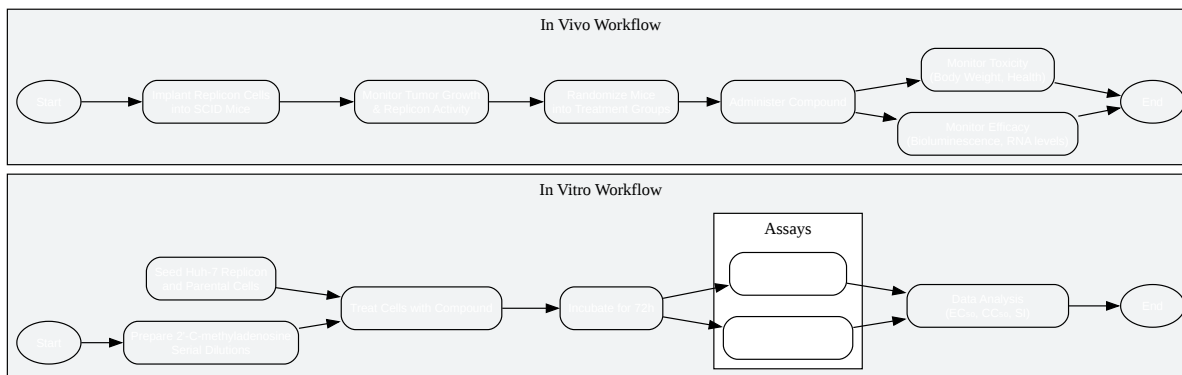

[Click to download full resolution via product page](#)

Caption: Experimental workflow for in vitro and in vivo efficacy testing.

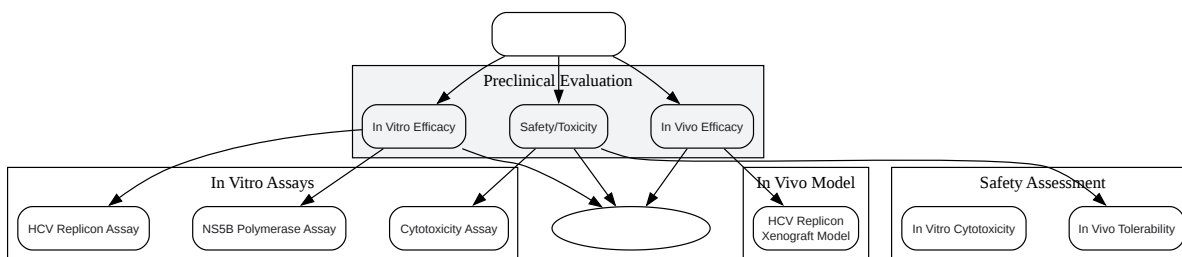

[Click to download full resolution via product page](#)

Caption: Logical relationship of experimental design for drug development.

Need Custom Synthesis?

BenchChem offers custom synthesis for rare earth carbides and specific isotopic labeling.

Email: info@benchchem.com or [Request Quote Online](#).

References

- [1. 2.3. Cell Cytotoxicity Assay and Half-Maximal Cytotoxic Concentration \(CC50\) Determination \[bio-protocol.org\]](#)
- [2. HCV Replicons: Overview and Basic Protocols | Springer Nature Experiments \[experiments.springernature.com\]](#)
- [3. pubcompare.ai \[pubcompare.ai\]](#)
- [4. HCV replicons: overview and basic protocols - PubMed \[pubmed.ncbi.nlm.nih.gov\]](#)
- [5. Frontiers | HCV Replicon Systems: Workhorses of Drug Discovery and Resistance \[frontiersin.org\]](#)
- [6. CC50/IC50 Assay for Antiviral Research - Creative Diagnostics \[antiviral.creative-diagnostics.com\]](#)
- [7. labinsights.nl \[labinsights.nl\]](#)
- [8. Specific inhibitors of HCV polymerase identified using an NS5B with lower affinity for template/primer substrate - PMC \[pmc.ncbi.nlm.nih.gov\]](#)
- [9. Novel Robust Hepatitis C Virus Mouse Efficacy Model - PMC \[pmc.ncbi.nlm.nih.gov\]](#)
- [10. scilit.com \[scilit.com\]](#)
- [11. Hepatitis C RNA Quantitative Testing: Test of Hepatitis C - Viral Hepatitis and Liver Disease \[hepatitis.va.gov\]](#)
- To cite this document: BenchChem. [Application Notes and Protocols for Testing 2'-C-methyladenosine Efficacy]. BenchChem, [2026]. [Online PDF]. Available at: [\[https://www.benchchem.com/product/b103435/docs#application-notes-and-protocols-for-testing-2-c-methyladenosine-efficacy\]](https://www.benchchem.com/product/b103435/docs#application-notes-and-protocols-for-testing-2-c-methyladenosine-efficacy)

Disclaimer & Data Validity:

The information provided in this document is for Research Use Only (RUO) and is strictly not intended for diagnostic or therapeutic procedures. While BenchChem strives to provide accurate protocols, we make no warranties, express or implied, regarding the fitness of this product for every specific experimental setup.

Technical Support: The protocols provided are for reference purposes. Unsure if this reagent suits your experiment?

Need Industrial/Bulk Grade? [Request Custom Synthesis Quote](#)

BenchChem

Our mission is to be the trusted global source of essential and advanced chemicals, empowering scientists and researchers to drive progress in science and industry.

Contact

Address: 3281 E Guasti Rd
Ontario, CA 91761, United States
Phone: (601) 213-4426
Email: info@benchchem.com

[Contact our Ph.D. Support Team for a compatibility check](#)