

Advanced Structural Verification: ¹H NMR Profiling of (3-Chloropropyl)ethyl(methyl)amine

Author: BenchChem Technical Support Team. **Date:** May 2026

Compound of Interest

Compound Name: (3-Chloropropyl)ethyl(methyl)amine
CAS No.: 343926-41-0
Cat. No.: B103826

[Get Quote](#)

Executive Summary

Compound: **(3-Chloropropyl)ethyl(methyl)amine** Molecular Formula: C₆H₁₄ClN Application: Alkylating agent in pharmaceutical synthesis (e.g., psychotropic drugs). Analytical Challenge: Distinguishing the intact alkyl chloride from its hydrolysis product (alcohol) and confirming the tertiary amine formation from secondary amine precursors.

This guide compares the ¹H NMR performance of the target molecule against common "alternatives" (impurities and precursors) encountered during drug development. It demonstrates why ¹H NMR is the superior method for establishing salt stoichiometry and structural integrity compared to LC-MS alone.

Part 1: Structural Analysis & Predicted Shifts

The molecule consists of three distinct steric environments around the central nitrogen: a methyl group, an ethyl group, and a 3-chloropropyl chain.

1.1 The Molecular Assignment (Free Base in CDCl₃)

Note: Chemical shifts (

) are approximate and concentration-dependent.

Label	Proton Group	Integration	Multiplicity	Approx. Shift (ppm)	Structural Insight
A	N-CH ₃	3H	Singlet (s)	2.20 – 2.25	Sharp singlet; diagnostic for N-methylation.
B	N-CH ₂ -CH ₃	2H	Quartet (q)	2.40 – 2.50	Overlaps frequently with proton D.
C	N-CH ₂ -CH ₃	3H	Triplet (t)	1.00 – 1.10	Classic triplet; clear of interference.
D	N-CH ₂ -CH ₂ ...	2H	Triplet (t)	2.40 – 2.50	The -methylene of the propyl chain.
E	...CH ₂ -CH ₂ -CH ₂ ...	2H	Multiplet (m)	1.85 – 2.00	Quintet-like; sensitive to chain length.
F	...CH ₂ -CH ₂ -Cl	2H	Triplet (t)	3.55 – 3.65	Deshielded by Chlorine. Critical Quality Attribute.

1.2 Visualization of Assignments

The following diagram maps the structural logic to the NMR signals.

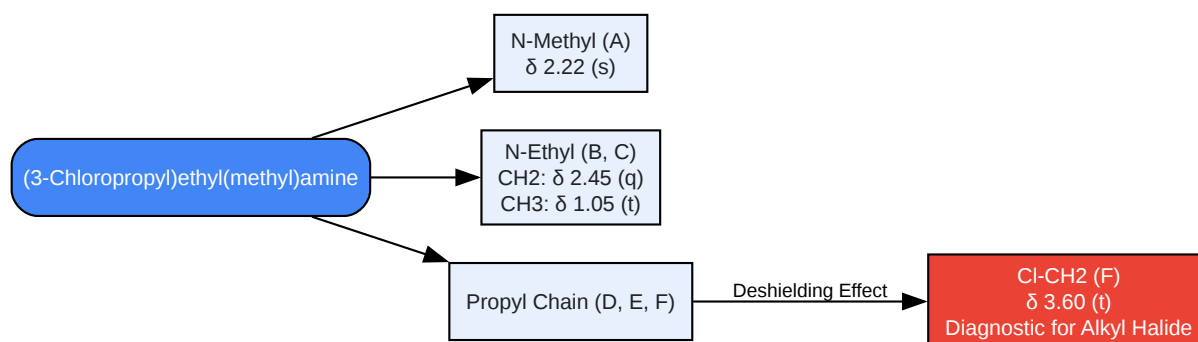

[Click to download full resolution via product page](#)

Caption: Structural decomposition of NMR signals. The Cl-CH₂ moiety (Red) is the primary indicator of functional integrity.

Part 2: Comparative Performance Analysis

In drug development, "performance" is defined by the ability to distinguish the product from impurities.

Comparison 1: Target vs. Hydrolysis Impurity (The Alcohol)

Alternative: (3-Hydroxypropyl)ethyl(methyl)amine. Context: Alkyl chlorides hydrolyze to alcohols in the presence of moisture/base. Performance Metric: Resolution of the terminal methylene.

Feature	Target (Alkyl Chloride)	Alternative (Alcohol Impurity)	Diagnostic Action
Terminal CH ₂ Shift	3.60 ppm (Triplet)	3.60 – 3.75 ppm (Triplet)	High Risk: Shifts are very similar.
OH Signal	Absent	Present (Broad singlet, solvent dependent)	Run in DMSO-d ₆ to see OH coupling.
Central CH ₂ (Beta)	~1.95 ppm	~1.65 – 1.75 ppm	Best Indicator: The -protons shift upfield in the alcohol.

Expert Insight: Do not rely solely on the terminal CH₂ shift, as Cl and OH have similar electronegativity effects. Focus on the central methylene (Group E). In the alcohol, the shielding effect is different, causing a noticeable upfield shift compared to the chloride.

Comparison 2: Free Base vs. HCl Salt

Alternative: (3-Chloropropyl)ethyl(methyl)ammonium chloride. Context: The drug intermediate is often stored as a salt for stability. Performance Metric: Shift magnitude of N-adjacent protons.

- Free Base: N-CH₂ protons appear at 2.4 – 2.5 ppm.
- HCl Salt: Protonation of the Nitrogen exerts a strong electron-withdrawing effect. N-CH₂ protons shift downfield to 3.0 – 3.2 ppm.
- Protocol: If the spectrum shows broad peaks >3.0 ppm for the ethyl group, perform a "D₂O Shake." If the peaks sharpen or move, you are observing exchangeable salt protons.

Comparison 3: 1H NMR vs. LC-MS

Context: Deciding which method to use for purity release.

Feature	1H NMR	LC-MS	Winner
Salt Stoichiometry	Direct measurement (Integration of counter-ion vs. drug)	Indirect/Invisible (Salts dissociate)	NMR
Structural Isomers	Distinguishes branched vs. linear propyl chains via coupling	Often identical mass/fragmentation	NMR
Trace Impurities	Limit of detection ~0.1%	Limit of detection <0.01%	LC-MS

Part 3: Experimental Protocol (Self-Validating)

To ensure reproducible data that can be cited in regulatory filings, follow this "Self-Validating" protocol.

3.1 Sample Preparation

- Solvent Choice: Use CDCl_3 (Chloroform-d) for the free base to ensure sharp coupling. Use DMSO-d6 if analyzing the HCl salt or looking for labile OH protons (hydrolysis check).
- Concentration: Dissolve 10-15 mg of sample in 0.6 mL solvent. Warning: Over-concentration (>30 mg) causes viscosity broadening, obscuring the ethyl quartet.
- Filtration: Filter through a glass wool plug to remove inorganic salts (e.g., NaCl from synthesis) which cause baseline distortion.

3.2 Acquisition Parameters

- Pulse Sequence: Standard 1H (zg30).
- Scans (NS): 16 (sufficient for >95% purity), 64 (for impurity profiling).
- Relaxation Delay (D1): Set to 5 seconds.
 - Reasoning: The Methyl singlet (Group A) has a long T1 relaxation time. Short delays lead to under-integration of the methyl group, falsely suggesting a secondary amine impurity.

3.3 Validation Workflow (Decision Tree)

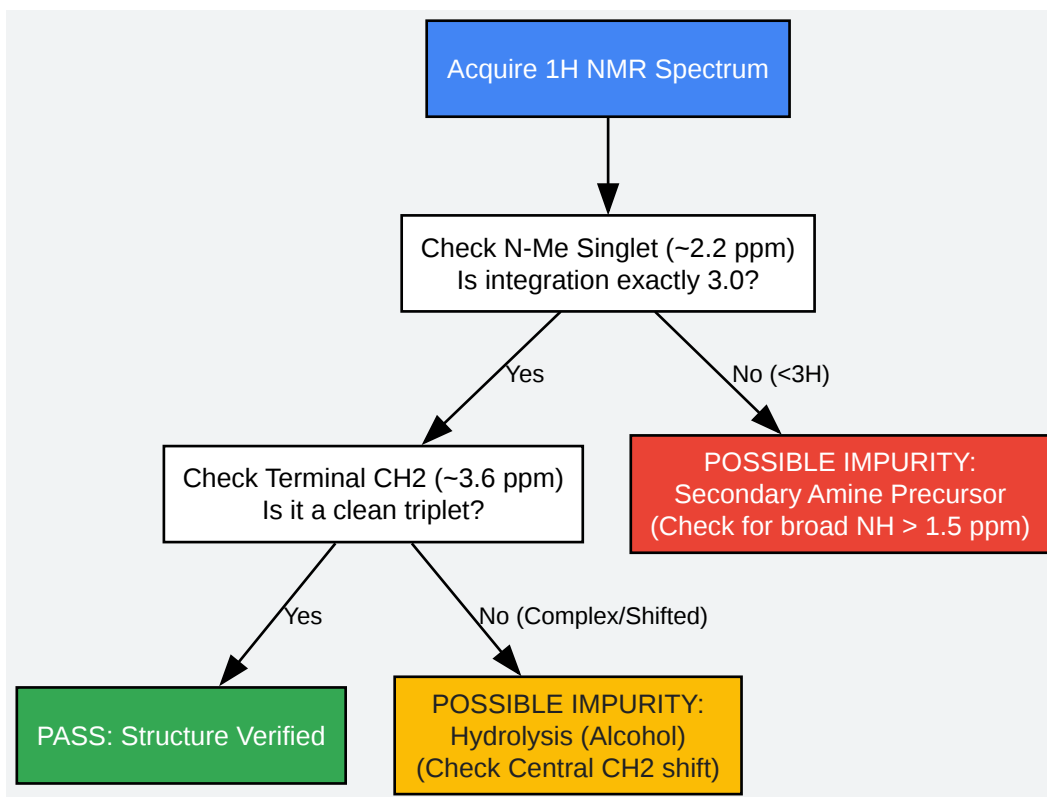

[Click to download full resolution via product page](#)

Caption: Logic flow for validating **(3-Chloropropyl)ethyl(methyl)amine** integrity.

References

- National Institute of Advanced Industrial Science and Technology (AIST). (n.d.). Spectral Database for Organic Compounds (SDBS).[1] Retrieved from [\[Link\]](#)
- PubChem. (n.d.).[2] **(3-Chloropropyl)ethyl(methyl)amine** Compound Summary. National Library of Medicine. Retrieved from [\[Link\]](#)
- Hesse, M., Meier, H., & Zeeh, B. (2008). Spectroscopic Methods in Organic Chemistry. Thieme. (Standard reference for chemical shift tables).
- Reich, H. J. (2024). Structure Determination Using NMR. University of Wisconsin-Madison. Retrieved from [\[Link\]](#)

Need Custom Synthesis?

BenchChem offers custom synthesis for rare earth carbides and specific isotopic labeling.

Email: info@benchchem.com or [Request Quote Online](#).

Sources

- 1. [1H NMR Chemical Shift \[sites.science.oregonstate.edu\]](https://sites.science.oregonstate.edu)
- 2. [\(3-Chloropropyl\)ethyl\(methyl\)amine | C6H14ClN | CID 12721790 - PubChem \[pubchem.ncbi.nlm.nih.gov\]](https://pubchem.ncbi.nlm.nih.gov)
- To cite this document: BenchChem. [Advanced Structural Verification: 1H NMR Profiling of (3-Chloropropyl)ethyl(methyl)amine]. BenchChem, [2026]. [Online PDF]. Available at: [\[https://www.benchchem.com/product/b103826/docs#advanced-structural-verification-1h-nmr-profiling-of-3-chloropropyl-ethyl-methyl-amine\]](https://www.benchchem.com/product/b103826/docs#advanced-structural-verification-1h-nmr-profiling-of-3-chloropropyl-ethyl-methyl-amine)

Disclaimer & Data Validity:

The information provided in this document is for Research Use Only (RUO) and is strictly not intended for diagnostic or therapeutic procedures. While BenchChem strives to provide accurate protocols, we make no warranties, express or implied, regarding the fitness of this product for every specific experimental setup.

Technical Support: The protocols provided are for reference purposes. Unsure if this reagent suits your experiment?

Need Industrial/Bulk Grade? [Request Custom Synthesis Quote](#)

BenchChem

Our mission is to be the trusted global source of essential and advanced chemicals, empowering scientists and researchers to drive progress in science and industry.

Contact

Address: 3281 E Guasti Rd

Ontario, CA 91761, United States

Phone: (601) 213-4426

Email: info@benchchem.com

Contact our Ph.D. Support Team for a compatibility check