

Topic: Genetic Regulation of Cholesteryl Palmitoleate Metabolism

Author: BenchChem Technical Support Team. **Date:** May 2026

Compound of Interest

Compound Name: *Cholesteryl palmitoleate*

CAS No.: 16711-66-3

Cat. No.: B102256

[Get Quote](#)

Abstract

Cholesteryl palmitoleate, a specific cholesteryl ester, sits at the crossroads of cholesterol and fatty acid metabolism. Its synthesis and degradation are tightly controlled by a sophisticated network of enzymes and transcription factors that respond to cellular nutrient status. Dysregulation of this network is intrinsically linked to the pathophysiology of prevalent metabolic diseases, including atherosclerosis and non-alcoholic fatty liver disease (NAFLD). This technical guide provides a comprehensive overview of the core enzymatic machinery and the genetic regulatory circuits, primarily the Sterol Regulatory Element-Binding Protein (SREBP) and Liver X Receptor (LXR) pathways, that govern **cholesteryl palmitoleate** homeostasis. We further explore insights from human genetic studies and present detailed, field-proven experimental protocols for investigating these pathways, offering a robust framework for researchers and drug development professionals aiming to understand and therapeutically target this critical metabolic nexus.

Part 1: The Central Role of Cholesteryl Palmitoleate in Lipid Homeostasis

Cholesteryl palmitoleate is a neutral lipid molecule formed through the esterification of a cholesterol molecule with palmitoleic acid (a 16-carbon monounsaturated omega-7 fatty acid). [1] This process converts cholesterol, an essential but potentially toxic amphipathic molecule, into a more inert, hydrophobic form that can be safely stored within cytosolic lipid droplets or packaged into lipoproteins for transport.

The metabolism of **cholesteryl palmitoleate** is not merely a passive storage mechanism; it is a dynamic process central to:

- **Buffering Free Cholesterol:** Esterification is the primary mechanism by which cells protect themselves from the cytotoxic effects of excess free cholesterol.
- **Energy and Lipid Storage:** Lipid droplets, rich in cholesteryl esters and triglycerides, serve as a key energy reserve.
- **Lipoprotein Assembly:** The formation of cholesteryl esters is crucial for the assembly and secretion of very-low-density lipoproteins (VLDL) by the liver.
- **Pathophysiological Processes:** The accumulation of cholesteryl esters in macrophages is a hallmark of foam cell formation, the foundational step in the development of atherosclerotic plaques.[2] Furthermore, circulating levels of palmitoleic acid and its esterified forms are increasingly recognized as biomarkers and mediators in metabolic syndrome and NAFLD.[3]

Part 2: The Enzymatic Machinery: Synthesis and Hydrolysis

The steady-state level of **cholesteryl palmitoleate** is determined by the balanced activities of two key enzyme classes responsible for its synthesis and breakdown.

Esterification Pathway (Synthesis)

The synthesis of cholesteryl esters is catalyzed by Acyl-CoA:cholesterol acyltransferases (ACATs), also known as sterol O-acyltransferases (SOATs).[4] These enzymes are located in the endoplasmic reticulum (ER) and utilize long-chain fatty acyl-CoAs (such as palmitoleoyl-CoA) and cholesterol as substrates.

- SOAT1 (ACAT1): Expressed ubiquitously, SOAT1 is vital for maintaining intracellular cholesterol homeostasis in most tissues.
- SOAT2 (ACAT2): Primarily expressed in the liver and intestine, SOAT2 plays a specialized role in the assembly and secretion of lipoproteins.

The inhibition of these enzymes is a therapeutic strategy being explored to reduce cholesterol absorption and atherosclerotic plaque formation.[2]

Hydrolytic Pathway (Breakdown)

The cleavage of the ester bond to release free cholesterol and palmitoleic acid is performed by cholesteryl ester hydrolases (CEHs).[5][6] These enzymes are critical for mobilizing stored cholesterol for use in steroidogenesis, membrane synthesis, or efflux from the cell.

- Neutral Cholesteryl Ester Hydrolase (nCEH): The primary enzyme responsible for cholesteryl ester hydrolysis in the cytosol.
- Lysosomal Acid Lipase (LAL): Encoded by the LIPA gene, this enzyme hydrolyzes cholesteryl esters and triglycerides that enter the cell via lipoprotein endocytosis within the lysosome.[5]

Table 1: Key Enzymes in Cholesteryl Palmitoleate Metabolism

Process	Enzyme	Gene	Cellular Location	Primary Function
Synthesis	Acyl-CoA:cholesterol acyltransferase 1	SOAT1	Endoplasmic Reticulum	Intracellular cholesterol esterification
Synthesis	Acyl-CoA:cholesterol acyltransferase 2	SOAT2	Endoplasmic Reticulum	Lipoprotein assembly (Liver, Intestine)
Hydrolysis	Neutral Cholesteryl Ester Hydrolase	CES1 (and others)	Cytosol	Mobilization of stored cholesterol
Hydrolysis	Lysosomal Acid Lipase	LIPA	Lysosome	Breakdown of lipoprotein-derived esters

Part 3: Core Genetic Regulatory Networks

The expression of the enzymes described above, along with the entire machinery for synthesizing the cholesterol and palmitoleate substrates, is governed by a sophisticated interplay of transcription factors that sense and respond to cellular lipid levels.

The SREBP Pathway: Master Regulator of Lipid Synthesis

Sterol Regulatory Element-Binding Proteins (SREBPs) are the master transcriptional activators of genes required for cholesterol and fatty acid synthesis.[\[7\]](#)[\[8\]](#)[\[9\]](#)

- SREBP-2: This isoform preferentially activates genes involved in cholesterol biosynthesis (e.g., HMGCR, HMGCS1) and uptake (LDLR).[\[7\]](#)[\[10\]](#)
- SREBP-1c: This isoform primarily drives the expression of genes required for fatty acid synthesis (e.g., ACLY, ACC, FASN) and desaturation (SCD1), which produces monounsaturated fatty acids like palmitoleic acid.[\[7\]](#)[\[10\]](#) Insulin is a potent activator of SREBP-1c expression, linking carbohydrate intake to fat storage.[\[11\]](#)

The activation of SREBPs is a classic example of regulated intramembrane proteolysis. When ER cholesterol levels are low, an escort protein called SCAP (SREBP Cleavage-Activating Protein) transports the SREBP precursor from the ER to the Golgi.[9][12] In the Golgi, two proteases cleave the SREBP, releasing its N-terminal domain, which translocates to the nucleus to activate target gene transcription.[9] When ER cholesterol is high, cholesterol binds to SCAP, causing it to bind to another ER-resident protein, Insig (Insulin-induced gene), which traps the SCAP-SREBP complex in the ER, preventing its activation.[9][12]

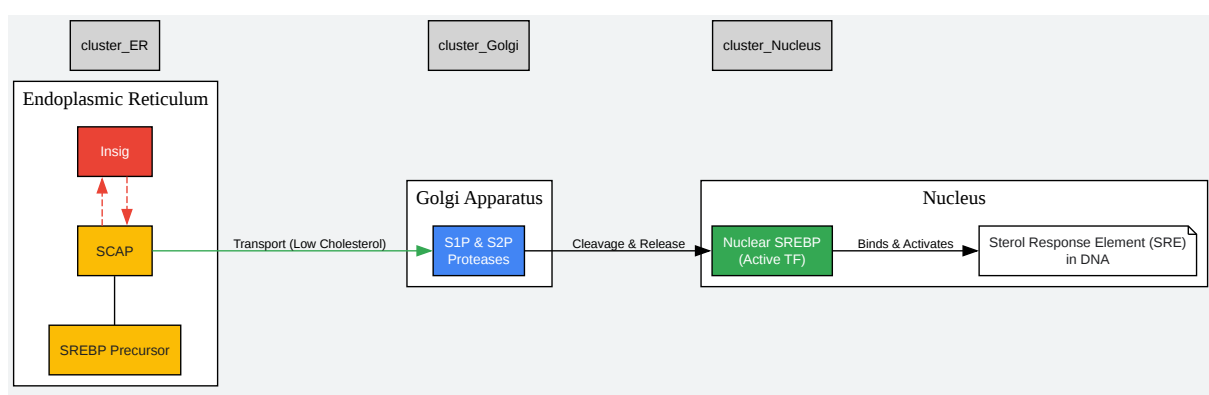

[Click to download full resolution via product page](#)

SREBP activation pathway in response to cellular sterol levels.

The LXR Pathway: Cholesterol Sensing and Response

Liver X Receptors (LXR α and LXR β) are nuclear receptors that function as cellular cholesterol sensors.[13][14] They are activated by oxysterols, which are oxidized derivatives of cholesterol that accumulate when cellular cholesterol levels are high.[14][15]

Upon activation, LXRs form a heterodimer with the Retinoid X Receptor (RXR) and bind to LXR Response Elements (LXREs) in the promoters of target genes.[14] Key functions of LXR activation include:

- Promoting Reverse Cholesterol Transport: LXRs upregulate genes like ABCA1 and ABCG1, which encode transporters that efflux cholesterol out of cells to HDL particles.[16]
- Inducing Lipogenesis: Crucially, LXR activation strongly induces the expression of SREBF1 (the gene for SREBP-1c).[7][13] This provides a direct mechanistic link between cholesterol excess and the synthesis of fatty acids. The cell's logic is to convert the excess cholesterol into cholesteryl esters for safe storage by providing the necessary fatty acid substrates.

This LXR-SREBP-1c axis is a critical control point in **cholesteryl palmitoleate** metabolism, ensuring that the components for its synthesis are available when cholesterol needs to be detoxified and stored.

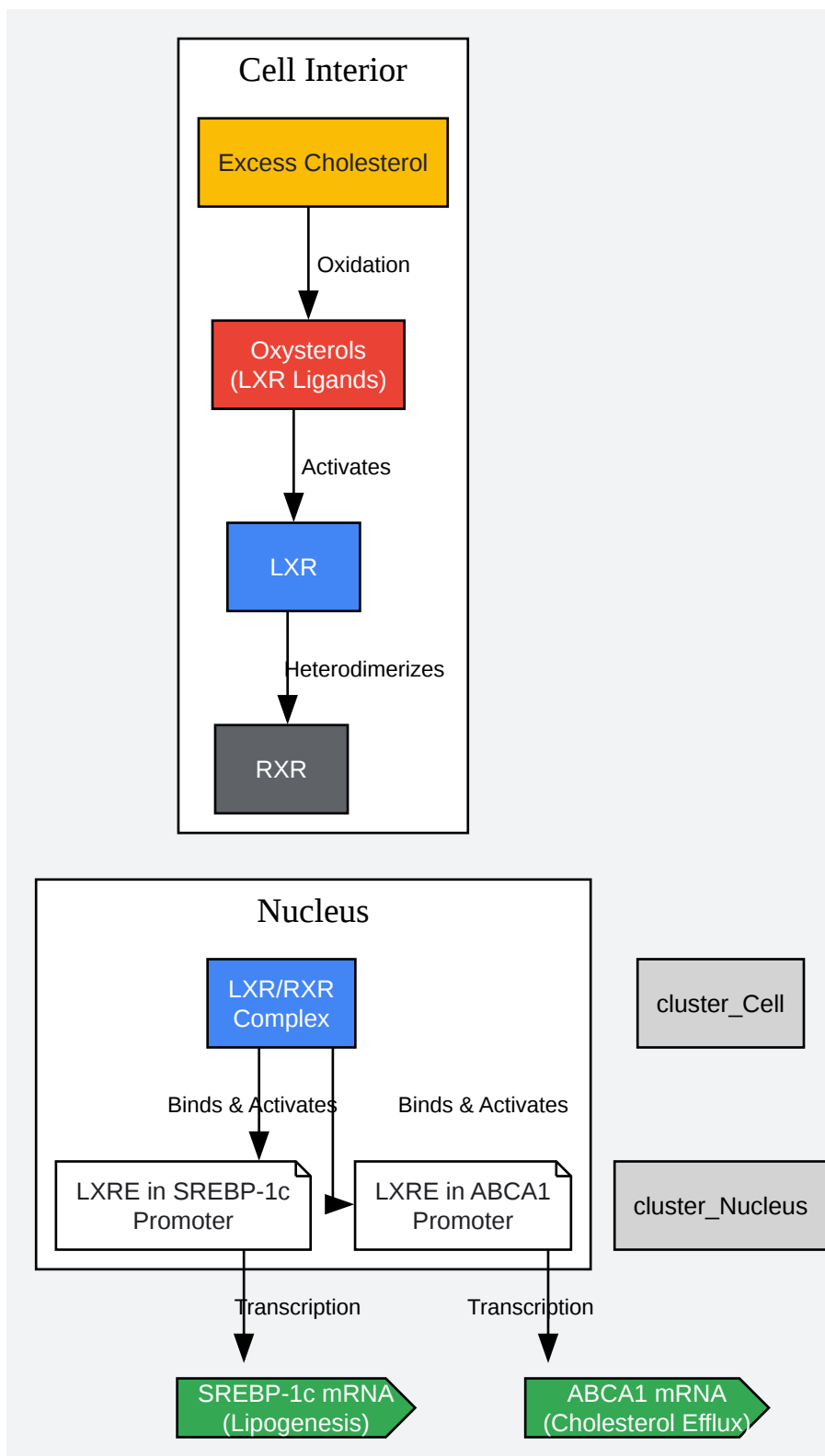

[Click to download full resolution via product page](#)

LXR signaling pathway in response to excess cholesterol.

Part 4: Human Genetic Evidence and Disease Correlation

Genome-Wide Association Studies (GWAS) have provided invaluable, unbiased insights into the genetic architecture of lipid metabolism, identifying novel loci that influence circulating levels of cholesteryl esters and their fatty acid components.

A meta-analysis of GWAS for plasma phospholipid fatty acids identified several loci associated with palmitoleic acid (16:1n-7) levels.^[17] These findings highlight genes involved in diverse biological processes, underscoring the complexity of fatty acid regulation.

Table 2: Selected GWAS Loci Associated with Palmitoleic Acid (16:1n-7) Levels

Locus (Nearest Gene)	SNP	Function of Gene	Reference
FADS1 / FADS2	rs102275	Fatty acid desaturases involved in PUFA synthesis	[17]
GCKR	rs1260326	Glucokinase regulator, links glucose and lipid metabolism	[17]
PKD2L1	rs603424	Polycystic kidney disease 2-like 1, function in lipid metabolism is novel	[17]
HIF1AN	rs11190604	Factor inhibiting hypoxia-inducible factor-1, links metabolism to oxygen sensing	[17]

These genetic findings provide a powerful starting point for functional studies to elucidate the precise mechanisms by which these genes influence **cholesteryl palmitoleate** metabolism

and contribute to cardiometabolic disease risk.

Part 5: Experimental Methodologies for Investigation

A multi-pronged approach combining lipidomics, gene expression analysis, and functional genetics is essential for dissecting the regulation of **cholesteryl palmitoleate** metabolism.

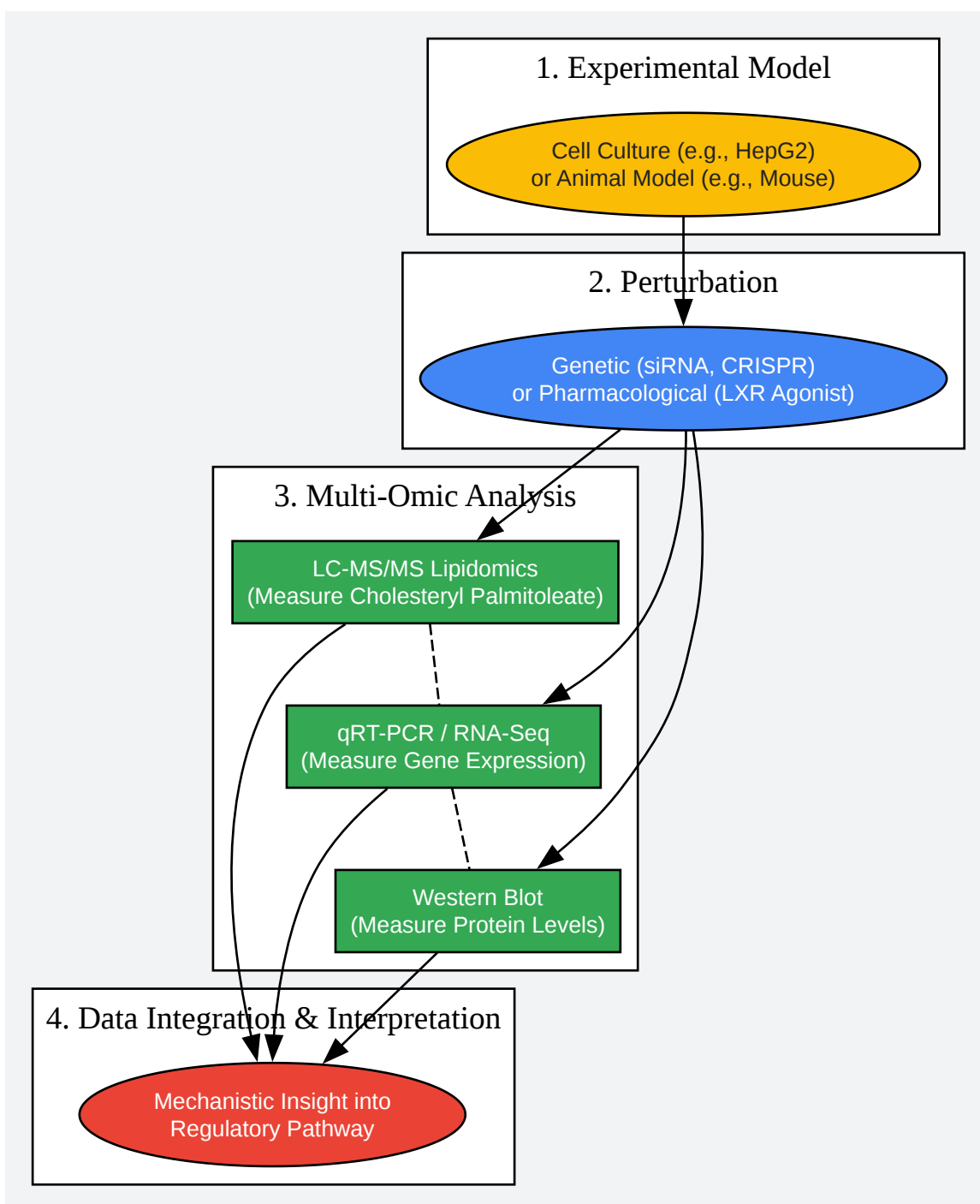

[Click to download full resolution via product page](#)

Integrated experimental workflow for studying lipid metabolism.

Protocol 1: Lipidomic Analysis of Cholesteryl Esters via LC-MS/MS

This protocol provides a robust method for quantifying **cholesteryl palmitoleate** in biological samples.^[18]

Causality: This method is chosen for its high sensitivity and specificity, allowing for the precise identification and quantification of individual lipid species within a complex mixture.

- Lipid Extraction:
 - Homogenize ~20 mg of tissue or 20 μ L of plasma in a glass vial.
 - Add 1 mL of a 2:1 (v/v) mixture of chloroform:methanol containing an appropriate internal standard (e.g., d7-cholesteryl oleate).
 - Vortex vigorously for 2 minutes and incubate at room temperature for 30 minutes.
 - Add 200 μ L of 0.9% NaCl solution, vortex for 1 minute, and centrifuge at 2,000 x g for 10 minutes to separate phases.
 - Carefully collect the lower organic phase into a new glass vial.
 - Dry the lipid extract under a stream of nitrogen gas.
- Sample Reconstitution:
 - Reconstitute the dried lipid film in 100 μ L of a 9:1 (v/v) mixture of methanol:chloroform.
- LC-MS/MS Analysis:
 - Inject 5 μ L of the reconstituted sample onto a C18 reverse-phase HPLC column (e.g., 2.1 x 100 mm, 1.8 μ m particle size).

- Use a gradient elution with mobile phase A (e.g., acetonitrile:water with 10 mM ammonium formate) and mobile phase B (e.g., isopropanol:acetonitrile with 10 mM ammonium formate).
- Perform detection using a tandem mass spectrometer in positive ion mode, monitoring for the specific precursor-to-product ion transition for **cholesteryl palmitoleate** (and the internal standard).
- Data Analysis:
 - Quantify the peak area of **cholesteryl palmitoleate** relative to the peak area of the internal standard.
 - Normalize the final value to the initial sample weight or volume.

Protocol 2: Analysis of Gene Expression using qRT-PCR

This protocol measures the mRNA levels of key regulatory genes.

Causality: qRT-PCR is the gold standard for accurate and sensitive quantification of gene expression changes, providing direct evidence of transcriptional regulation.

- RNA Extraction:
 - Isolate total RNA from cultured cells or tissues using a TRIzol-based method or a commercial column-based kit, following the manufacturer's instructions.
 - Assess RNA quality and quantity using a spectrophotometer (A260/280 ratio) and/or microfluidic electrophoresis.
- cDNA Synthesis:
 - Synthesize first-strand cDNA from 1 µg of total RNA using a reverse transcriptase kit with oligo(dT) and/or random hexamer primers.
- Quantitative PCR (qPCR):

- Prepare a reaction mix containing cDNA template, forward and reverse primers for the target gene (e.g., SREBF2, SOAT1, LXR α) and a reference gene (e.g., ACTB, GAPDH), and a SYBR Green or probe-based qPCR master mix.
- Run the reaction on a real-time PCR instrument.
- Data Analysis:
 - Calculate the cycle threshold (Ct) for each gene.
 - Determine the relative gene expression using the $\Delta\Delta C_t$ method, normalizing the target gene expression to the reference gene.

Protocol 3: Functional Genetic Assays via siRNA Knockdown

This protocol assesses the functional role of a specific gene in **cholesteryl palmitoleate** metabolism.[\[19\]](#)

Causality: By specifically reducing the expression of a single gene, this method allows for a direct test of its causal role in a metabolic outcome.

- Cell Culture and Seeding:
 - Culture a relevant cell line (e.g., human hepatoma HepG2 cells) in appropriate media.
 - Seed cells in 12-well plates at a density that will result in 50-70% confluency at the time of transfection.
- siRNA Transfection:
 - Dilute a validated siRNA targeting the gene of interest (e.g., SREBF2) and a non-targeting control siRNA in serum-free media.
 - In a separate tube, dilute a lipid-based transfection reagent (e.g., Lipofectamine RNAiMAX) in serum-free media.

- Combine the diluted siRNA and transfection reagent, incubate for 15 minutes at room temperature to allow complex formation.
- Add the siRNA-lipid complexes dropwise to the cells.
- Incubation and Treatment:
 - Incubate the cells for 48-72 hours to allow for target gene knockdown.
 - During the last 16-24 hours, cells can be treated with relevant compounds (e.g., a lipid mixture containing palmitoleic acid) to stimulate the pathway.
- Harvest and Analysis:
 - Harvest the cells. Divide the cell pellet for parallel analysis.
 - Use one portion for RNA extraction and qRT-PCR to confirm target gene knockdown (Protocol 2).
 - Use the other portion for lipid extraction and LC-MS/MS analysis to measure the effect on **cholesteryl palmitoleate** levels (Protocol 1).

Part 6: Conclusion and Future Directions

The genetic regulation of **cholesteryl palmitoleate** metabolism is a highly integrated system orchestrated by the SREBP and LXR signaling pathways. These networks elegantly balance the synthesis, storage, and mobilization of this key lipid species in response to cellular nutrient cues. The deep understanding of these pathways, facilitated by the experimental approaches outlined here, has revealed critical nodes for therapeutic intervention. Targeting key enzymes like ACAT or modulating the activity of transcription factors like LXRs holds promise for treating metabolic diseases.^{[2][12]}

Future research should focus on elucidating the tissue-specific regulation of these pathways, exploring the roles of additional genetic loci identified through GWAS, and understanding how dietary and environmental factors intersect with these genetic networks to influence an individual's metabolic health.

References

A complete, numbered list of all cited sources with clickable URLs is provided below for verification.

- From Food to Genes: Transcriptional Regulation of Metabolism by Lipids and Carbohydr
- Liver X receptors in lipid signalling and membrane homeostasis - PMC. (n.d.). PubMed Central.
- From Food to Genes: Transcriptional Regulation of Metabolism by Lipids and Carbohydr
- Liver LXR α expression is crucial for whole body cholesterol homeostasis and reverse cholesterol transport in mice. (2012).
- Transcriptional regulation of lipid metabolism by fatty acids: a key determinant of pancreatic beta-cell function. (2005). *Nutrition & Metabolism*, 2(1), 1.
- Cholesterol Ester: Synthesis, Metabolism & Therapeutic Role. (n.d.).
- Liver X Receptors: Regulators of Cholesterol Metabolism, Inflammation, Autoimmunity, and Cancer. (n.d.). *Frontiers*.
- Regulation of cholesterol homeostasis by the liver X receptors in the central nervous system. (n.d.).
- Cholesteryl palmitole
- SREBPs: activators of the complete program of cholesterol and fatty acid synthesis in the liver - PMC. (n.d.). PubMed Central.
- Transcriptional Regulation of Metabolism. (2006). *Physiological Reviews*, 86(2), 465–514.
- Insulin and Transcriptional Regulation of Lipid Metabolism. (2022). *Encyclopedia.pub*.
- LXR regulation of brain cholesterol: from development to disease - PMC. (n.d.). PubMed Central.
- SREBPs in Lipid Metabolism, Insulin Signaling, and Beyond - PMC. (n.d.). PubMed Central.
- SREBP Regulation of Lipid Metabolism in Liver Disease, and Therapeutic Strategies. (n.d.).
- Role of the Sterol Regulatory Element Binding Protein Pathway in Tumorigenesis - PMC. (2020). PubMed Central.
- The SREBP Pathway: Gene Regulation through Sterol Sensing and Gated Protein Trafficking. (2009). Johns Hopkins University.
- CAS 601-34-3: Cholesteryl palmit
- **Cholesteryl Palmitoleate** (CAS 16711-66-3). (n.d.). Cayman Chemical.
- A study on cholesterol-cholesteryl ester metabolic homeostasis and drug intervention in hyperlipidemic hamsters using UHPLC-MS/MS. (2024). PubMed.
- GWAS and multi-omics integrative analysis reveal novel loci and their molecular mechanisms for circulating f
- Cholesterol Esterase. (n.d.). Worthington Enzyme Manual.

- Genome-Wide Association Study Identifies Novel Loci Associated With Concentrations of Four Plasma Phospholipid Fatty Acids in the De Novo Lipogenesis Pathway. (2013). Circulation: Cardiovascular Genetics, 6(1), 72–82.
- A study on cholesterol-cholesteryl ester metabolic homeostasis and drug intervention in hyperlipidemic hamsters using UHPLC-MS/MS. (2025).
- Genetic regulation of cholesterol homeostasis: chromosomal organization of candid
- Cholesterol Esterase. (n.d.).
- Genetic loci identified in GWAS with lipidome. Genetic loci identified... (n.d.).
- Serum palmitoleate acts as a lipokine in subjects at high cardiometabolic risk. (n.d.). PubMed.
- Cholesterol: from feeding to gene regul
- Hydrolysis reactions catalyzed by cholesterol esterases. (a) Hydrolysis of triacylglycerol into glycerol and fatty acids typically catalyzed by lipases. (b) Hydrolysis of cholesterol ester into cholesterol and fatty acid catalyzed by cholesterol esterases. (n.d.).
- RNAi–Based Functional Profiling of Loci from Blood Lipid Genome-Wide Association Studies Identifies Genes with Cholesterol-Regulatory FunctionRNAi of Lipid GWAS Uncovers Cholesterol Regul

Need Custom Synthesis?

BenchChem offers custom synthesis for rare earth carbides and specific isotopic labeling.

Email: info@benchchem.com or [Request Quote Online](#).

Sources

- [1. Cholesteryl palmitoleate | C43H74O2 | CID 13828666 - PubChem](#)
[pubchem.ncbi.nlm.nih.gov]
- [2. Cholesterol Ester: Synthesis, Metabolism & Therapeutic Role - Creative Proteomics](#)
[creative-proteomics.com]
- [3. Serum palmitoleate acts as a lipokine in subjects at high cardiometabolic risk - PubMed](#)
[pubmed.ncbi.nlm.nih.gov]
- [4. Genetic regulation of cholesterol homeostasis: chromosomal organization of candidate genes - PubMed](#) [pubmed.ncbi.nlm.nih.gov]
- [5. Cholesterol Esterase - Worthington Enzyme Manual | Worthington Biochemical](#)
[worthington-biochem.com]

- [6. researchgate.net \[researchgate.net\]](#)
- [7. SREBPs: activators of the complete program of cholesterol and fatty acid synthesis in the liver - PMC \[pmc.ncbi.nlm.nih.gov\]](#)
- [8. SREBPs in Lipid Metabolism, Insulin Signaling, and Beyond - PMC \[pmc.ncbi.nlm.nih.gov\]](#)
- [9. Cholesterol: from feeding to gene regulation - PMC \[pmc.ncbi.nlm.nih.gov\]](#)
- [10. SREBP Regulation of Lipid Metabolism in Liver Disease, and Therapeutic Strategies - PMC \[pmc.ncbi.nlm.nih.gov\]](#)
- [11. encyclopedia.pub \[encyclopedia.pub\]](#)
- [12. Role of the Sterol Regulatory Element Binding Protein Pathway in Tumorigenesis - PMC \[pmc.ncbi.nlm.nih.gov\]](#)
- [13. Liver X receptors in lipid signalling and membrane homeostasis - PMC \[pmc.ncbi.nlm.nih.gov\]](#)
- [14. Frontiers | Liver X Receptors: Regulators of Cholesterol Metabolism, Inflammation, Autoimmunity, and Cancer \[frontiersin.org\]](#)
- [15. semanticscholar.org \[semanticscholar.org\]](#)
- [16. JCI - Liver LXRA expression is crucial for whole body cholesterol homeostasis and reverse cholesterol transport in mice \[jci.org\]](#)
- [17. ahajournals.org \[ahajournals.org\]](#)
- [18. A study on cholesterol-cholesteryl ester metabolic homeostasis and drug intervention in hyperlipidemic hamsters using UHPLC-MS/MS - PubMed \[pubmed.ncbi.nlm.nih.gov\]](#)
- [19. BioKB - Publication \[biokb.lcsb.uni.lu\]](#)
- To cite this document: BenchChem. [Topic: Genetic Regulation of Cholesteryl Palmitoleate Metabolism]. BenchChem, [2026]. [Online PDF]. Available at: [\[https://www.benchchem.com/product/b102256/docs#topic-genetic-regulation-of-cholesteryl-palmitoleate-metabolism\]](https://www.benchchem.com/product/b102256/docs#topic-genetic-regulation-of-cholesteryl-palmitoleate-metabolism)

Disclaimer & Data Validity:

The information provided in this document is for Research Use Only (RUO) and is strictly not intended for diagnostic or therapeutic procedures. While BenchChem strives to provide accurate protocols, we make no warranties, express or implied, regarding the fitness of this product for every specific experimental setup.

Technical Support: The protocols provided are for reference purposes. Unsure if this reagent suits your experiment?

Need Industrial/Bulk Grade? [Request Custom Synthesis Quote](#)

BenchChem

Our mission is to be the trusted global source of essential and advanced chemicals, empowering scientists and researchers to drive progress in science and industry.

Contact

Address: 3281 E Guasti Rd
Ontario, CA 91761, United States
Phone: (601) 213-4426
Email: info@benchchem.com

[Contact our Ph.D. Support Team for a compatibility check](#)