

Application Note: Vilsmeier-Haack Formylation of Chromanones for 3-Substitution

Author: BenchChem Technical Support Team. **Date:** April 2026

Compound of Interest

Compound Name: *2,3-Dihydro-3-methyl-4H-1-benzopyran-4-one*

CAS No.: 16982-86-8

Cat. No.: B101049

[Get Quote](#)

Target Audience: Researchers, Scientists, and Drug Development Professionals Document

Type: Detailed Technical Guide & Experimental Protocol

Strategic Context & Introduction

The chromanone and chromone heterocyclic cores are privileged scaffolds in medicinal chemistry, forming the structural backbone of numerous natural flavonoids, homoisoflavonoids, and synthetic therapeutic agents[1]. Functionalization at the C3 position of these oxygen-containing heterocycles is a critical step in drug development, as the C3-substituent (particularly a formyl group) serves as a highly reactive electrophilic handle for downstream cross-coupling, Schiff base formation, and heterocycle annulation[2][3].

The Vilsmeier-Haack (VH) reaction is the premier synthetic methodology for introducing a formyl group at the C3 position. However, the exact nature of the 3-substitution is heavily dependent on the starting material. This application note details the mechanistic divergence, optimized protocols, and causality behind the VH formylation of 4-chromanones versus acyclic o-hydroxyacetophenone precursors.

Mechanistic Divergence: Substrate-Dependent 3-Substitution

The Vilsmeier-Haack reaction utilizes a highly electrophilic chloromethyleniminium ion (the Vilsmeier reagent), generated in situ from

-dimethylformamide (DMF) and phosphorus oxychloride (

).

The structural outcome of the 3-substitution depends entirely on whether the substrate is a pre-formed cyclic 4-chromanone or an acyclic precursor.

Pathway A: 4-Chromanones to 4-Chloro-2H-chromene-3-carbaldehydes

When the VH reaction is applied directly to 4-chromanones, the substrate first undergoes tautomerization to its enol form. The Vilsmeier reagent attacks the nucleophilic C3 position. Because

is present in the reaction mixture, it acts as a chlorinating agent, replacing the C4 enolic hydroxyl group with a chloride ion[4]. The resulting product is 4-chloro-2H-chromene-3-carbaldehyde. This dual formylation-chlorination event provides a highly valuable intermediate where both the C3-formyl and C4-chloro groups can be orthogonally functionalized.

Pathway B: o-Hydroxyacetophenones to 3-Formylchromones

To synthesize a pure 3-formylchromone without C4-chlorination, the VH reaction is typically applied to o-hydroxyacetophenones[2]. This pathway involves a double formylation of the methyl group, followed by an intramolecular cyclization with the phenolic hydroxyl group. The subsequent elimination of dimethylamine yields the fully aromatic 3-formylchromone.

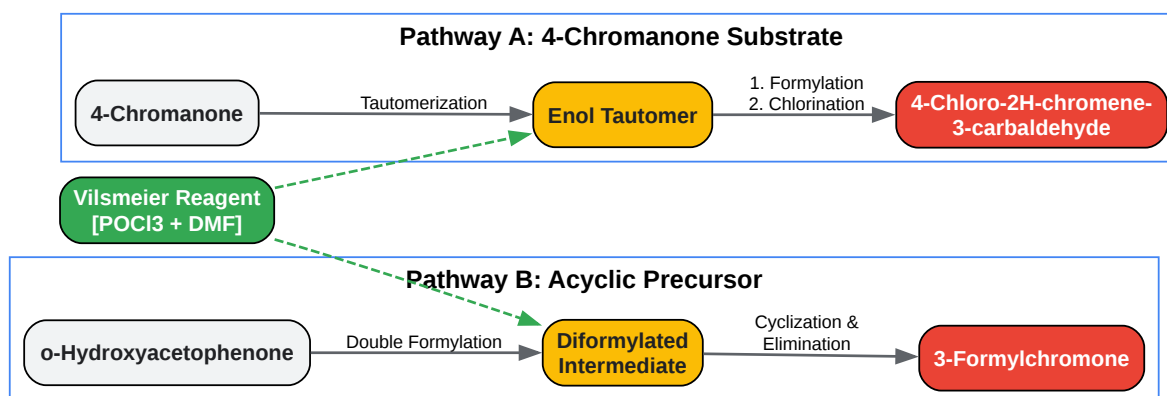

[Click to download full resolution via product page](#)

Caption: Mechanistic divergence of the Vilsmeier-Haack reaction based on substrate selection.

Experimental Protocols: Self-Validating Systems

The following protocols are designed with self-validating checkpoints to ensure the integrity of the sensitive iminium intermediates.

Protocol A: Synthesis of 4-Chloro-2H-chromene-3-carbaldehyde from 4-Chromanone[4][5]

Rationale: This protocol utilizes excess

to drive both the formylation and the C4-chlorination of the 4-chromanone core.

- Vilsmeier Reagent Generation:
 - Action: In an oven-dried, argon-purged round-bottom flask, add anhydrous DMF (3.0 equiv) and cool to 0 °C using an ice-water bath. Add (2.5 equiv) dropwise over 15 minutes.

- Causality: The formation of the chloromethyleniminium ion is highly exothermic. Maintaining 0 °C prevents the thermal decomposition of the reagent and suppresses the formation of unwanted dimethylamine byproducts.
- Substrate Addition:
 - Action: Dissolve 4-chromanone (1.0 equiv) in a minimal amount of anhydrous DMF. Add this solution dropwise to the Vilsmeier reagent at 0 °C. Stir for 30 minutes.
- Thermal Activation:
 - Action: Remove the ice bath and heat the reaction mixture to 70–80 °C for 2 to 4 hours. Monitor via TLC (Hexane/EtOAc 3:1).
 - Causality: Thermal energy is required to overcome the activation barrier for the electrophilic attack on the enol tautomer and the subsequent chlorination step.
- Hydrolytic Quenching:
 - Action: Cool the mixture to room temperature, then pour it slowly over crushed ice containing saturated aqueous sodium acetate ().
 - Causality: Ice absorbs the exothermic shock of hydrolysis. The buffer is critical; it provides a mildly basic environment to hydrolyze the iminium salt into the final aldehyde without causing base-catalyzed ring-opening of the newly formed chromene ring.
- Isolation:
 - Action: Extract the aqueous layer with Ethyl Acetate (). Wash the combined organic layers with brine, dry over anhydrous , and concentrate under reduced pressure. Purify via silica gel column chromatography.

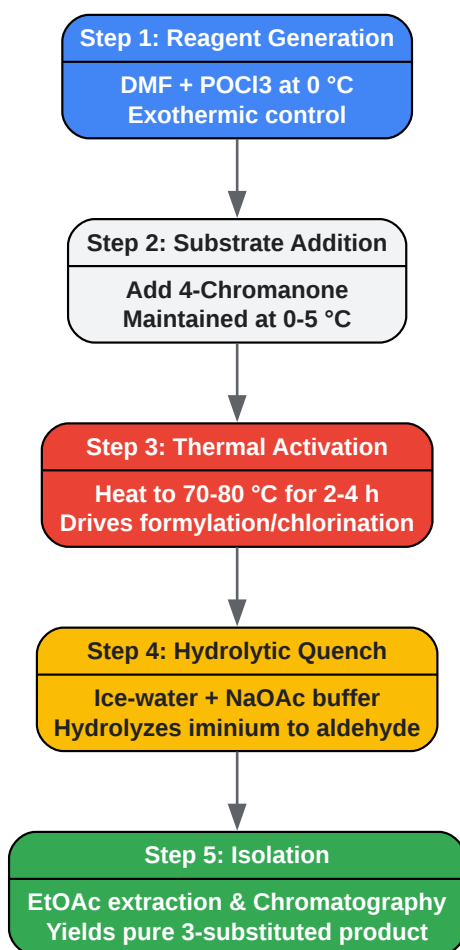

[Click to download full resolution via product page](#)

Caption: Step-by-step experimental workflow for the Vilsmeier-Haack formylation of 4-chromanone.

Quantitative Data & Optimization Matrix

To optimize the 3-substitution, the choice of chlorinating agent and temperature profile must be strictly controlled. Table 1 summarizes the quantitative outcomes based on literature-validated parameters^{[2][4]}.

Table 1: Optimization Matrix for 3-Substitution via Vilsmeier-Haack

Substrate	Reagents (Equiv)	Temp / Time	Primary Product	Typical Yield	Key Mechanistic Note
4-Chromanone	(2.5) / DMF (3.0)	80 °C / 3 h	4-Chloro-2H-chromene-3-carbaldehyde	85 - 87%	acts as both formylating activator and chlorinating agent.
4-Chromanone	Oxalyl Chloride (2.0) / DMF	70 °C / 2 h	4-Chloro-2H-chromene-3-carbaldehyde	80 - 82%	Oxalyl chloride provides milder Vilsmeier generation; still yields 4-chloro product.
o-Hydroxyacetophenone	(3.0) / DMF (4.0)	55 °C / 5 h	3-Formylchromone	75 - 90%	Requires excess reagent for double formylation prior to cyclization.
7-Methoxy-4-chromanone	(2.5) / DMF (3.0)	80 °C / 4 h	4-Chloro-7-methoxy-2H-chromene-3-carbaldehyde	78 - 83%	EDG at C7 accelerates enolization, improving overall reaction kinetics.

Downstream Applications in Drug Development

The 3-substituted products generated from these protocols are not final therapeutics but rather highly specialized linchpins for complex molecular architectures:

- Synthesis of Chromenopyrazoles: 4-Chloro-2H-chromene-3-carbaldehydes react readily with hydrazine derivatives. The hydrazine first condenses with the C3-formyl group, followed by an intramolecular nucleophilic aromatic substitution () displacing the C4-chloride, yielding [1]benzopyrano[4,3-c]pyrazoles. These compounds exhibit potent anti-parasitic and anti-tumor activities[4].
- Schiff Base Ligands for Metallo drugs: 3-Formylchromones are frequently condensed with primary aromatic amines to form Schiff bases. These ligands are utilized to synthesize Copper(II) complexes, which demonstrate significant biomimetic catalytic properties and enhanced cytotoxicity against breast cancer cell lines[2].
- Azlactone Formation: Condensation of 2H-chromene-3-carbaldehydes with hippuric acid yields 2H-chromenylphenyloxazolones, which are potent free radical scavengers and -glucosidase inhibitors utilized in anti-diabetic research.

References

- Advances in chromone-based copper(II) Schiff base complexes: synthesis, characterization, and versatile applications in pharmacology and biomimetic catalysis Source: RSC Publishing URL:[2](#)
- Synthetic Routes to Coumarin(Benzopyrone)
-Pyrone Moiety. Part II Source: PMC (NIH) URL:[3](#)
- Ruthenium-Catalyzed C–H Activation of Salicylaldehyde and Decarboxylative Coupling of Alkynoic Acids for the Selective Synthesis of Homoisoflavonoids and Flavones Source: ACS Publications (Organic Letters) URL:[1](#)
- [1]benzopyrano[4,3-c]pyrazole Cryptosporidium parvum inosine 5 Source: Amazon S3 (Supplementary Research Data) URL:[4](#)
- Synthesis, free radical scavenging and

-glucosidase inhibitory activities of 2H-chromenylphenyloxazolones Source: NIScPR URL:

Need Custom Synthesis?

BenchChem offers custom synthesis for rare earth carbides and specific isotopic labeling.

Email: info@benchchem.com or [Request Quote Online](#).

Sources

- [1. pubs.acs.org \[pubs.acs.org\]](https://pubs.acs.org)
- [2. Advances in chromone-based copper\(ii \) Schiff base complexes: synthesis, characterization, and versatile applications in pharmacology and biomimetic ... - RSC Advances \(RSC Publishing\) DOI:10.1039/D4RA00590B \[pubs.rsc.org\]](#)
- [3. Synthetic Routes to Coumarin\(Benzopyrone\)-Fused Five-Membered Aromatic Heterocycles Built on the \$\alpha\$ -Pyrone Moiety. Part II: Five-Membered Aromatic Rings with Multi Heteroatoms - PMC \[pmc.ncbi.nlm.nih.gov\]](#)
- [4. s3-eu-west-1.amazonaws.com \[s3-eu-west-1.amazonaws.com\]](https://s3-eu-west-1.amazonaws.com)
- To cite this document: BenchChem. [Application Note: Vilsmeier-Haack Formylation of Chromanones for 3-Substitution]. BenchChem, [2026]. [Online PDF]. Available at: [\[https://www.benchchem.com/product/b101049/docs#application-note-vilsmeier-haack-formylation-of-chromanones-for-3-substitution\]](https://www.benchchem.com/product/b101049/docs#application-note-vilsmeier-haack-formylation-of-chromanones-for-3-substitution)

Disclaimer & Data Validity:

The information provided in this document is for Research Use Only (RUO) and is strictly not intended for diagnostic or therapeutic procedures. While BenchChem strives to provide accurate protocols, we make no warranties, express or implied, regarding the fitness of this product for every specific experimental setup.

Technical Support: The protocols provided are for reference purposes. Unsure if this reagent suits your experiment?

Need Industrial/Bulk Grade? [Request Custom Synthesis Quote](#)

BenchChem

Our mission is to be the trusted global source of essential and advanced chemicals, empowering scientists and researchers to drive progress in science and industry.

Contact

Address: 3281 E Guasti Rd

Ontario, CA 91761, United States

Phone: (601) 213-4426

Email: info@benchchem.com

[Contact our Ph.D. Support Team for a compatibility check](#)