

# Sunitinib Malate Formulation Technical Support Center

**Author:** BenchChem Technical Support Team. **Date:** December 2025

## Compound of Interest

Compound Name: Sunitinib Malate

Cat. No.: B000624

[Get Quote](#)

Welcome to the technical support center for **Sunitinib Malate**. This resource is designed to assist researchers, scientists, and drug development professionals with the formulation and experimental use of **Sunitinib Malate**. Here you will find troubleshooting guides and frequently asked questions (FAQs) to address common issues encountered during research.

## Frequently Asked Questions (FAQs)

Q1: How should I dissolve **Sunitinib Malate** for in vitro experiments?

A1: **Sunitinib Malate** is soluble in organic solvents such as DMSO and dimethyl formamide.[1] For in vitro studies, a common practice is to prepare a high-concentration stock solution in DMSO.[2] For example, a 100 mM stock solution can be prepared in DMSO.[2] It is sparingly soluble in aqueous buffers.[1] To prepare an aqueous working solution, it is recommended to first dissolve **Sunitinib Malate** in DMSO and then dilute it with the aqueous buffer of choice.[1] For instance, a solubility of approximately 0.25 mg/ml can be achieved in a 1:3 solution of DMSO:PBS (pH 7.2).[1] It is not recommended to store the aqueous solution for more than one day.[1]

Q2: What is the recommended storage condition for **Sunitinib Malate**?

A2: **Sunitinib Malate** should be stored at -20°C as a crystalline solid for long-term stability (≥4 years).[1] Stock solutions in DMSO should be stored at -80°C for up to 2 years or -20°C for up to 1 year, in sealed storage, away from moisture.[3] To avoid repeated freeze-thaw cycles, it is advisable to aliquot the stock solutions.[4]

Q3: What are the primary cellular targets of **Sunitinib Malate**?

A3: **Sunitinib Malate** is a multi-targeted receptor tyrosine kinase (RTK) inhibitor.<sup>[5][6]</sup> Its primary targets include platelet-derived growth factor receptors (PDGFR $\alpha$  and PDGFR $\beta$ ), vascular endothelial growth factor receptors (VEGFR1, VEGFR2, and VEGFR3), stem cell factor receptor (KIT), FMS-like tyrosine kinase-3 (FLT3), colony-stimulating factor 1 receptor (CSF-1R), and the glial cell line-derived neurotrophic factor receptor (RET).<sup>[6][7][8]</sup>

## Troubleshooting Guide

Issue	Possible Cause	Suggested Solution
Precipitation of Sunitinib Malate in aqueous media.	Sunitinib Malate has low aqueous solubility.[1]	Prepare a high-concentration stock solution in DMSO and then dilute it to the final working concentration in your aqueous medium just before use. Ensure the final DMSO concentration is compatible with your experimental system and include a vehicle control (DMSO alone) in your experiments. For maximum solubility in aqueous buffers, first dissolve in DMSO and then dilute.[1]
Inconsistent or unexpected results in cell-based assays.	1. Degradation of Sunitinib Malate in working solutions. 2. Incorrect dosage or concentration. 3. Cell line sensitivity.	1. Prepare fresh working solutions from a frozen stock for each experiment. Do not store aqueous solutions for more than a day.[1] 2. Verify the concentration of your stock solution and perform a dose-response curve to determine the optimal concentration for your specific cell line and assay. IC50 values can vary between cell lines.[2] 3. Different cell lines can exhibit varying sensitivity to Sunitinib Malate.[2] Ensure the cell line you are using expresses the target receptors of Sunitinib.

---

Difficulty dissolving Sunitinib Malate for in vivo studies.	The formulation for in vivo use requires specific vehicles to ensure solubility and bioavailability.	For oral administration in animal models, Sunitinib Malate can be dissolved in 0.9% saline to a concentration of 3 mg/mL.[2] Another option is to prepare a suspension in carboxymethyl cellulose or a solution in a citrate buffer (pH 3.5).[3] Formulations with DMSO, PEG300, Tween-80, and saline, or with DMSO and corn oil have also been described.[3]
---	--	---

---

Observed cytotoxicity is lower than expected.	The drug may be interacting with components of the cell culture media, such as serum proteins.	The binding of sunitinib to human plasma protein is high (95%).[8] Consider reducing the serum concentration in your media during the treatment period, if your experimental design allows. Always include appropriate controls.
---	--	--

---

## Quantitative Data Summary

Table 1: Solubility of **Sunitinib Malate**

Solvent	Concentration	Notes
DMSO	≥ 15 mg/mL (28.17 mM)[3]	Fresh DMSO is recommended as moisture-absorbing DMSO can reduce solubility.[4]
Water	12.5 mg/mL (23.47 mM)	Requires sonication and pH adjustment to 3 with HCl.[3]
Water	3.33 mg/mL (6.25 mM)	Requires sonication and warming to 60°C.[3]
100 mM Citrate Buffer	10 mg/mL (18.78 mM)	Forms a suspended solution; requires sonication and pH adjustment to 5 with HCl.[3]
10% DMSO >> 40% PEG300 >> 5% Tween-80 >> 45% saline	≥ 2.5 mg/mL (4.69 mM)	Clear solution for in vivo use. [3]
10% DMSO >> 90% corn oil	≥ 2.5 mg/mL (4.69 mM)	Clear solution for in vivo use. [3]
DMSO:PBS (pH 7.2) (1:3)	~0.25 mg/mL	Prepared by first dissolving in DMSO then diluting.[1]

Table 2: In Vitro Inhibitory Activity of Sunitinib

Target	IC50 / Ki	Cell Line / Assay Condition
VEGFR2 (Flk-1)	IC50: 80 nM[4]	Cell-free assay[4]
PDGFR $\beta$	IC50: 2 nM[4]	Cell-free assay[4]
KIT	Ki: 4 nM[9]	
FLT3 (Wild-Type)	IC50: 250 nM[4]	
FLT3-ITD	IC50: 50 nM[4]	
HUVEC Proliferation (VEGF-induced)	IC50: 40 nM[4]	
NIH-3T3 (PDGFR $\beta$ overexpressing) Proliferation	IC50: 39 nM[4]	
HCT116	IC50: 31.18 $\mu$ M[2]	Cell viability assay[2]
RKO	IC50: 5.61 $\mu$ M[2]	Cell viability assay[2]

## Experimental Protocols

### Cell Proliferation Assay (CCK-8/MTT)

This protocol is adapted from a study on colorectal cancer cell lines.[2]

- Seed cells (e.g., HCT116 or RKO) at a density of  $3 \times 10^3$  cells/well in 96-well plates.
- Culture for 24 hours to allow for cell attachment.
- Treat the cells with **Sunitinib Malate** at specified concentrations for 24 hours. Include a vehicle-only control.
- Assess cell viability using a CCK-8 or MTT assay kit according to the manufacturer's instructions.
- Measure the absorbance at the appropriate wavelength (450 nm for CCK-8 or 490 nm for MTT) using a microplate reader.
- Calculate the cell survival rate as a percentage of the vehicle-treated control.

## In Vitro Kinase Assay

This is a general protocol to determine the kinase inhibitory activity of Sunitinib.

- Use 96-well microtiter plates pre-coated with a peptide substrate (e.g., poly-Glu,Tyr (4:1)).[\[4\]](#)
- Block excess protein binding sites with a blocking agent like BSA.[\[4\]](#)
- Add the purified target kinase (e.g., GST-VEGFR2 or GST-PDGFR $\beta$ ) to the wells.[\[4\]](#)
- Add diluted **Sunitinib Malate** at a range of concentrations to the reaction wells.
- Initiate the kinase reaction by adding ATP.
- Incubate the plates to allow for phosphorylation.
- Stop the reaction and wash the plates.
- Detect the amount of phosphotyrosine using a specific antibody (e.g., anti-phosphotyrosine antibody) followed by a secondary antibody conjugated to a detection enzyme (e.g., HRP).[\[4\]](#)
- Add a substrate for the detection enzyme and measure the signal to quantify kinase activity.

## Visualizations

### Sunitinib Malate Mechanism of Action

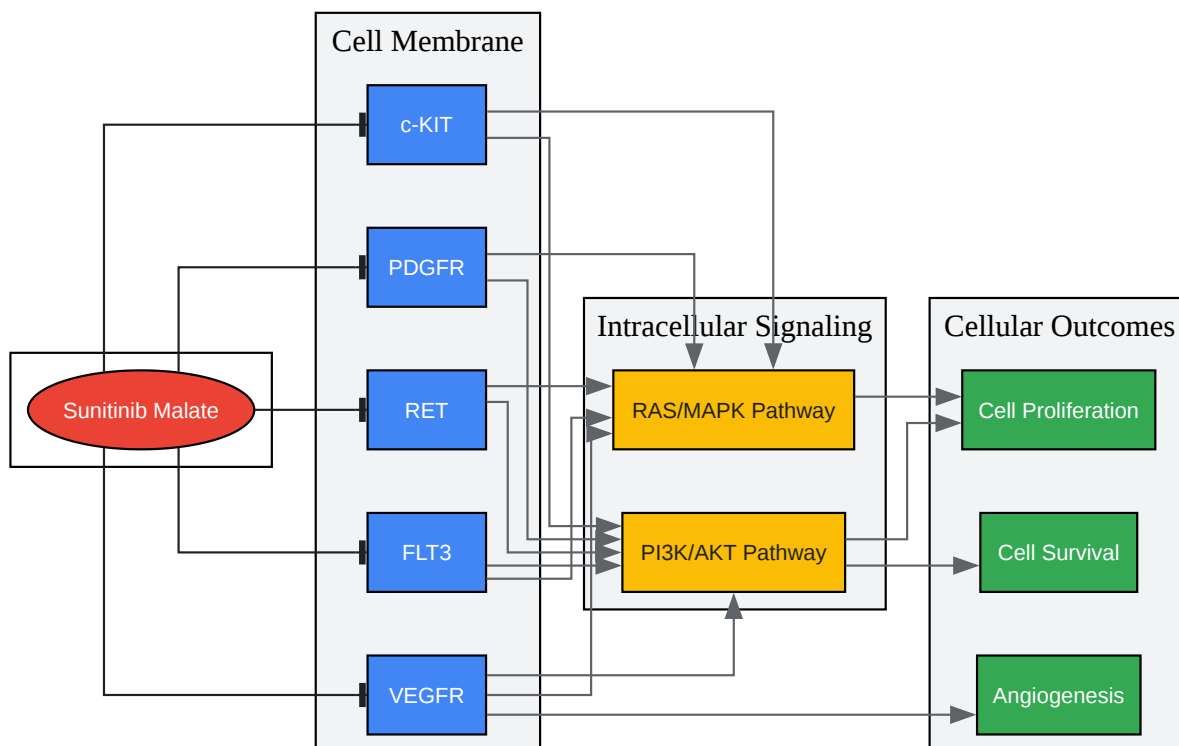



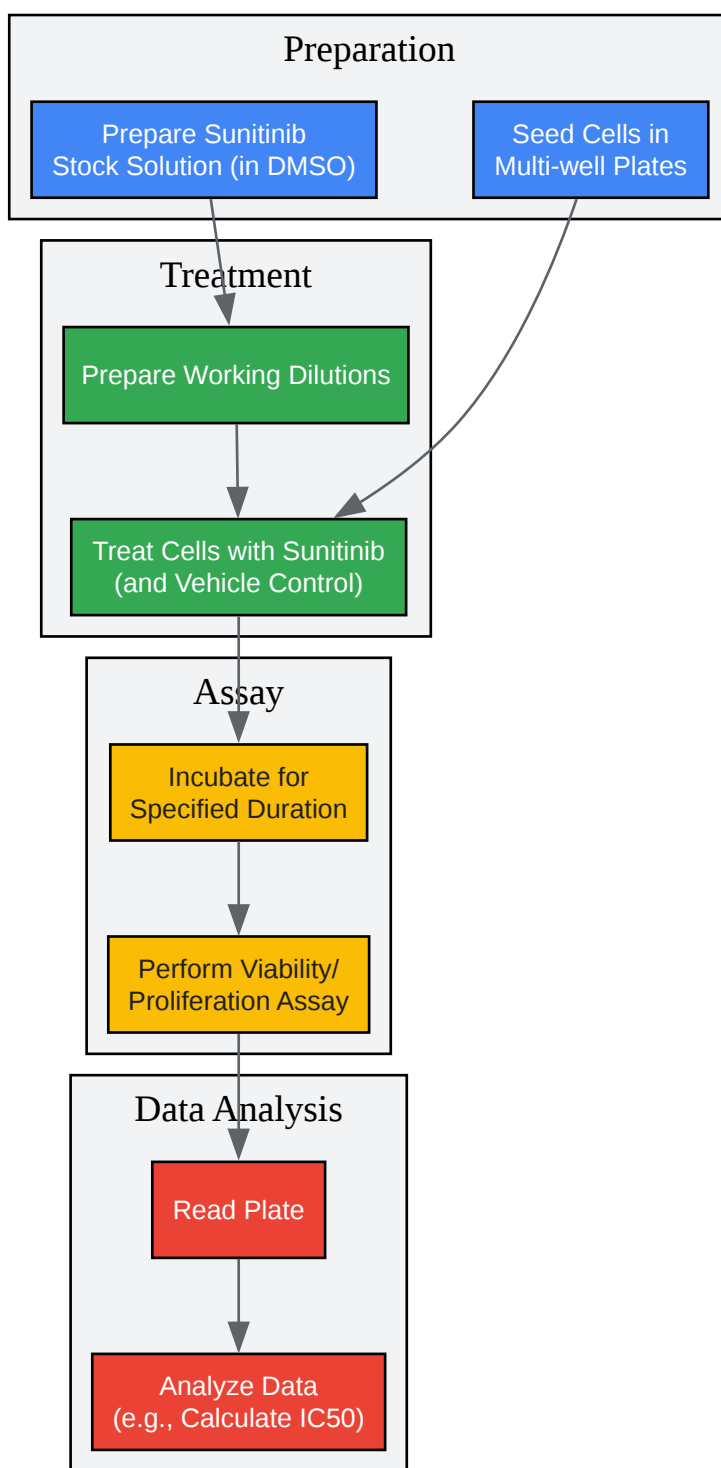

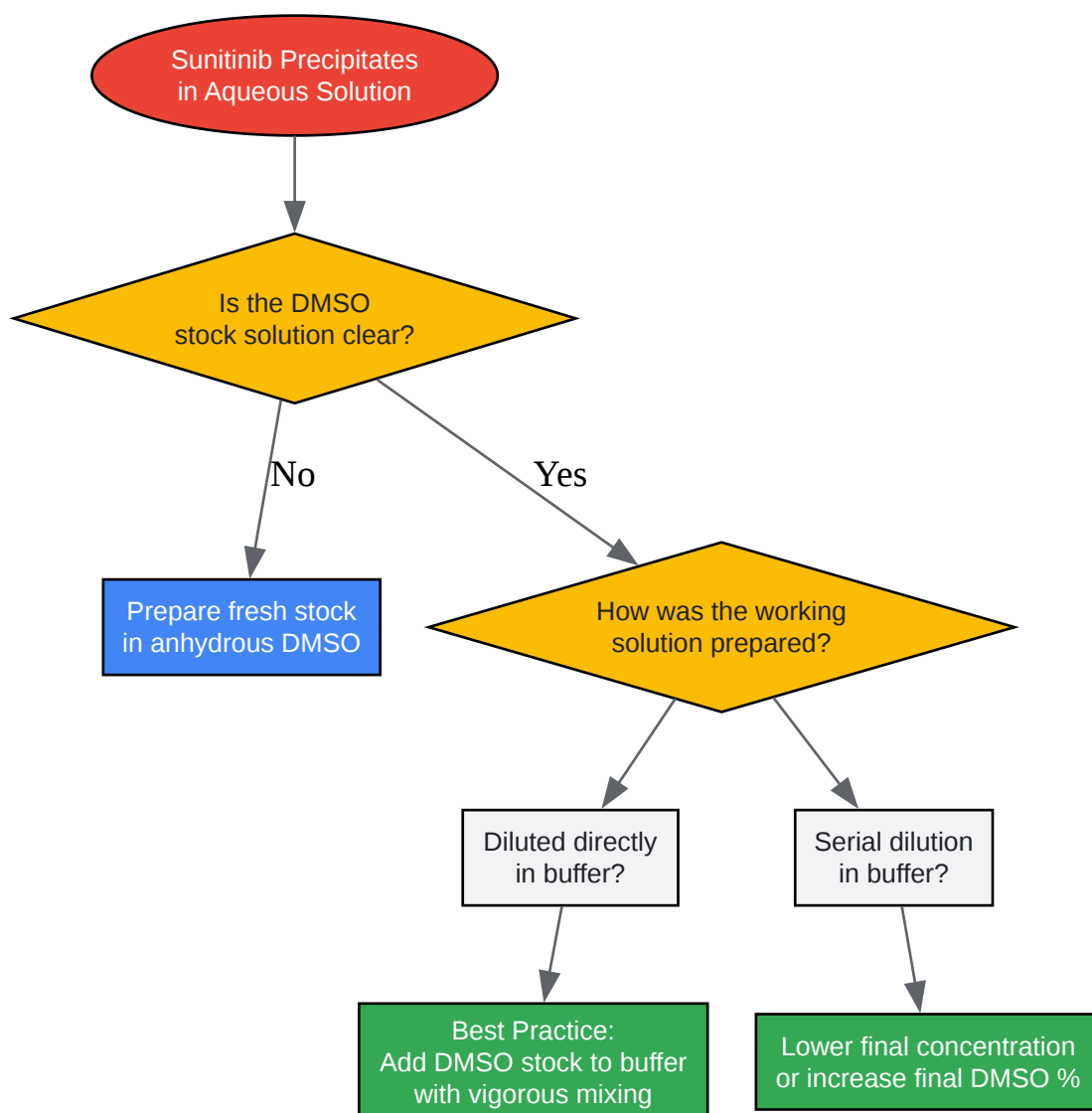

[Click to download full resolution via product page](#)

### Need Custom Synthesis?

BenchChem offers custom synthesis for rare earth carbides and specific isotopic labeling.

Email: [info@benchchem.com](mailto:info@benchchem.com) or [Request Quote Online](#).

## References

- 1. [cdn.caymanchem.com](http://cdn.caymanchem.com) [cdn.caymanchem.com]

- 2. Inhibition of colorectal carcinogenesis by sunitinib malate: disruption of the IL-6/STAT3/c-MYC/TWIST/MMP2 autocrine signaling axis - PMC [pmc.ncbi.nlm.nih.gov]
- 3. file.medchemexpress.com [file.medchemexpress.com]
- 4. selleckchem.com [selleckchem.com]
- 5. Sunitinib (Sutent, SU11248), a Small-Molecule Receptor Tyrosine Kinase Inhibitor, Blocks Function of the ATP-Binding Cassette (ABC) Transporters P-Glycoprotein (ABCB1) and ABCG2 - PMC [pmc.ncbi.nlm.nih.gov]
- 6. What is the mechanism of Sunitinib Malate? [synapse.patsnap.com]
- 7. aacrjournals.org [aacrjournals.org]
- 8. accessdata.fda.gov [accessdata.fda.gov]
- 9. Sunitinib malate | VEGFR | Tocris Bioscience [tocris.com]
- To cite this document: BenchChem. [Sunitinib Malate Formulation Technical Support Center]. BenchChem, [2025]. [Online PDF]. Available at: [https://www.benchchem.com/product/b000624#sunitinib-malate-formulation-for-research-use]

---

### Disclaimer & Data Validity:

The information provided in this document is for Research Use Only (RUO) and is strictly not intended for diagnostic or therapeutic procedures. While BenchChem strives to provide accurate protocols, we make no warranties, express or implied, regarding the fitness of this product for every specific experimental setup.

**Technical Support:** The protocols provided are for reference purposes. Unsure if this reagent suits your experiment? [[Contact our Ph.D. Support Team for a compatibility check](#)]

**Need Industrial/Bulk Grade?** [Request Custom Synthesis Quote](#)

# BenchChem

Our mission is to be the trusted global source of essential and advanced chemicals, empowering scientists and researchers to drive progress in science and industry.

## Contact

Address: 3281 E Guasti Rd

Ontario, CA 91761, United States

Phone: (601) 213-4426

Email: [info@benchchem.com](mailto:info@benchchem.com)